

# Model 475

Diaphragm Valve  
User Guide

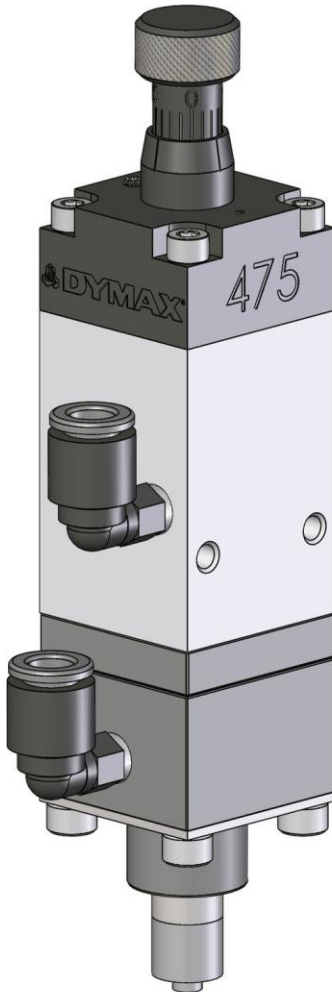

## About Dymax

### **UV/Visible light-curable adhesives. Systems for light curing, fluid dispensing, and fluid packaging.**

Dymax manufactures industrial adhesives, light-curable adhesives, epoxy resins, cyanoacrylates, and activator-cured adhesives. We also manufacture a complete line of manual fluid dispensing systems, automatic fluid dispensing systems, and light-curing systems. Light-curing systems include LED light sources, spot, flood, and conveyor systems designed for compatibility and high performance with Dymax adhesives.

Dymax adhesives and light-curing systems optimize the speed of automated assembly, allow for 100% in-line inspection, and increase throughput. System designs enable stand-alone configuration or integration into your existing assembly line.

Please note that most dispensing and curing system applications are unique. Dymax does not warrant the fitness of the product for the intended application. Any warranty applicable to the product, its application and use is strictly limited to that contained in the Dymax standard Conditions of Sale. Dymax recommends that any intended application be evaluated and tested by the user to insure that desired performance criteria are satisfied. Dymax is willing to assist users in their performance testing and evaluation. Data sheets are available for valve controllers or pressure pots upon request.

# Contents

- Contents..... 3**
- Introduction ..... 4**
  - Introduction to the User Guide ..... 4
  - Where to Get Help..... 4
- Safety..... 5**
  - General Safety Considerations ..... 5
  - Specific Safety Considerations ..... 5
- Product Overview..... 6**
  - Description of the Model 475 Dispensing Valve ..... 6
- Assembly and Setup ..... 7**
  - Unpacking and Inspecting Your Shipment ..... 7
  - Parts Included in the Model 475 Dispensing Valve..... 7
  - Mounting ..... 8
  - System Interconnect..... 8
  - Material Flow..... 9
- Operating the Dispensing Valve..... 10**
  - Operation ..... 10
  - Shutdown ..... 10
- Maintenance and Cleaning ..... 11**
  - General ..... 11
- Troubleshooting ..... 11**
- Spare Parts and Accessories ..... 12**
  - Options/Accessories ..... 12
  - Replacement Parts..... 12
- Specifications ..... 14**
  - Specifications..... 14
- Warranty..... 15**

# Introduction

## Introduction to the User Guide

This guide describes how to assemble, use, and maintain the Dymax Model 475 dispensing valve (T15988) safely and efficiently.

### Intended Audience

This user guide was prepared for experienced process engineers, maintenance technicians, and manufacturing personnel. If you are new to pneumatically operated fluid dispensing equipment and do not understand the instructions, contact Dymax Application Engineering to answer your questions before using the equipment.

## Where to Get Help

Additional resources are available to ensure a trouble-free experience with our products:

- Detailed product information on [www.dymax.com](http://www.dymax.com).
- Customer Support and Application Engineering teams are available by phone and email in the United States, Monday through Friday, from 8:00 a.m. to 5:30 p.m. Eastern Standard Time. You can also email Dymax at [info@dymax.com](mailto:info@dymax.com). See the back cover for worldwide contact information.
- Dymax adhesive Product Data Sheets (PDS) on our website.
- Material Safety Data Sheets (MSDS) sheets provided with shipments of Dymax adhesives.

# Safety



**WARNING!** *If you use this fluid dispensing equipment without first reading and understanding the information in this guide, personal injury can result from the uncontrolled release of high-pressure gas, injection injury, or exposure to chemicals. To reduce the risk of injury, read and understand this guide before assembling and using Dymax fluid dispensing equipment.*

## General Safety Considerations

All users of Dymax fluid dispensing equipment should read and understand this user guide before assembling and using the equipment.

To learn about the safe handling and use of dispensing fluids, obtain and read the MSDS for each fluid before using the fluid. Dymax includes an MSDS with each adhesive sold. MSDS for Dymax products can also be requested through the Dymax website.

## Specific Safety Considerations

### Using Safe Operating Pressures

Pressurizing the components in the dispensing system beyond the maximum recommended pressure can result in the rupturing of components and serious personal injury. To minimize the risk of rupturing components and injury, do not exceed the maximum operating pressure of the components in your fluid dispensing system (see system specifications on page 13).

### Preventing Injection Injury

Discharging fluids or compressed air with a dispensing tip against your skin can cause very serious injection injury. To minimize the risk of injection injury, do not place the dispensing tip in contact with your skin.

# Product Overview

## Description of the Model 475 Dispensing Valve

The Model 475 diaphragm valve is designed to be used with low- to high-viscosity fluids. The internal diaphragm design prevents fluid contact with actuating components within the valve. The 475 valve is ideal for reactive materials like cyanoacrylates and solvent-based products and provides consistent fluid deposits with minimal maintenance.

The Model 475 is ideally suited to automated applications, but can also be configured in a bench-top system with a DVC-345 valve controller and reservoir.

**Figure 1. Model 475 Internal Component Diagram**

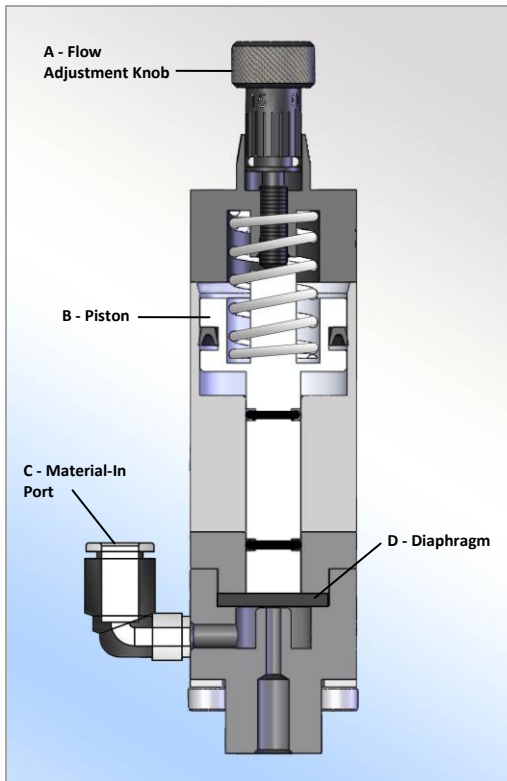

## Special Features and Benefits of the Model 475

Feature	Benefit
Internal diaphragm	Prevents fluid contact with actuating components within the valve
	Minimizes damage to the valve's actuating components and necessary maintenance
Stroke adjustment	Accurate, repeatable dispensing volumes

# Assembly and Setup

## Unpacking and Inspecting Your Shipment

When your Model 475 dispensing valve arrives, inspect the boxes for damage and notify the shipper of box damage immediately.

Open each box and check for equipment damage. If parts are damaged, notify the shipper and submit a claim for the damaged parts. Contact Dymax so that new parts can be shipped to you immediately.

Check that the parts included in your order match those listed below. If parts are missing, contact your local Dymax representative or Dymax Customer Support to resolve the problem.

## Parts Included in the Model 475 Dispensing Valve

- Model 475 diaphragm valve
- Assorted dispense tip kit
- Model 475 user guide

**Figure 2. Model 475 Diaphragm Valve**

## Mounting

**NOTE:** *If the dispense valve is to be mounted in an area that limits access to the valve, it is recommended that the set-up operation be done prior to mounting. Access to various surfaces of the valve is necessary for periodic adjustment (see Specifications).*

There are two 8-32 UNC holes on the dispense valve for mounting purposes (Figure 5).

## System Interconnect

### Air

Once the dispense valve is secured to its mounting surface, connect the airline to the port provided on the valve (Figure 3). Also connect your air supply (60-80 psi) to your valve controller or 3-way solenoid valve (a valve controller or a 3-way solenoid valve must be used



to operate the Model 475 valve (CV of .01 or greater)). Please refer to the valve controller user guide for detailed instructions.

## Fluid

The Model 475 diaphragm valve requires a material reservoir or pressure tank to draw material from. The material reservoir should be connected to the 475 valve through the material-in port (Figure 3) located on the valve body.

**Figure 3. Air and Fluid Connection Points**

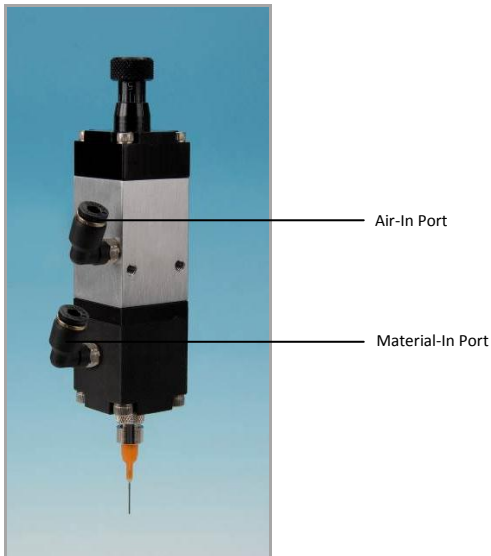

## Material Flow

### Adjusting Material Flow

Flow can be adjusted using the Flow Adjustment Knob (Figure 1, A). Turn the knob clockwise to decrease the flow or counterclockwise to increase flow.

# Operating the Dispensing Valve

## Operation

1. Plumb up the valve as outlined in the setup procedures.
2. Apply air pressure by turning on the pressure to the controller.
3. If necessary, place a new dispense tip onto the valve.
4. Apply fluid pressure to the valve by turning on the pressure to the material reservoir.
5. Cycle the valve to the open position to bleed all air that may have become trapped when changing the dispense tip. You may need to tip the valve up to 60° incline and continue cycling the air to remove it all.
5. Check the fluid connection for leaks. If the valve is leaking or dripping, refer to the troubleshooting section of this manual.
6. With the Flow Adjustment Knob (Figure 1, A) backed off counterclockwise 3 or 4 turns and the dispense tip in place, adjust the air pressure on the fluid (the valve will be in the open dispense position). Use the Flow Adjustment Knob to reduce the material flow until the desired flow rate is achieved.

## Shutdown

At the end of the day or shift, it is necessary to shut down the Model 475 dispensing system properly in order to keep material from curing inside the dispensing valve.

1. Remove the disposable dispense tip from valve and discard.
2. Relieve fluid pressure on the valve by turning off air pressure at the material reservoir.
3. Relieve the air pressure operating the valve by turning off the air pressure to the controller.

# Maintenance and Cleaning

## General

To clean the Model 475 valve, flush system with an appropriate solvent. For assistance in selecting a compatible solvent, please contact Dymax Application Engineering.

To access the valve's wetted components for cleaning or replacement, remove the four Allen Hex Cap Screws (Figure 4, 9) from the bottom of the valve.

# Troubleshooting

**Table 1. Troubleshooting Chart for Model 475 Dispensing Valve**

Problem	Possible Cause	Corrective Action
<b>The valve does not dispense anything</b>	The fluid pressure is too low	Increase the fluid pressure
	The material is cured in the valve or tip	Disassemble and clean the valve
<b>There are air bubbles in the fluid</b>	The valve is not properly purged	Point the valve up and cycle it until the air bubbles are removed
	There is a problem with the material reservoir and fluid delivery system	Diagnose and repair
<b>Material leaks from the valve tip</b>	The diaphragm is worn	Replace the diaphragm
	An air bubble is trapped in the fluid section of the valve or in the dispense tip	Point the valve up and cycle it until air bubbles are purged out

# Spare Parts and Accessories

## Options/Accessories

Item	Part Number
<b>Air Regulators</b>	
Air Filter Regulator	T16307
High-Precision Air Regulator	T16629
<b>Controllers</b>	
DVC-345 Digital Valve Controller	T11146
<b>Stands</b>	
Lab Stand – 24" [60.96 cm]	T15279
Valve Mounting Assembly for Lab Stand	T16857

## Replacement Parts

Item	Part Number
<b>Rebuild Kit</b>	
Valve Rebuild Kit	T16858
<b>Misc.</b>	
Diaphragm	T15317
O-Ring	T15323

Figure 4. Model 475 Replacement Parts

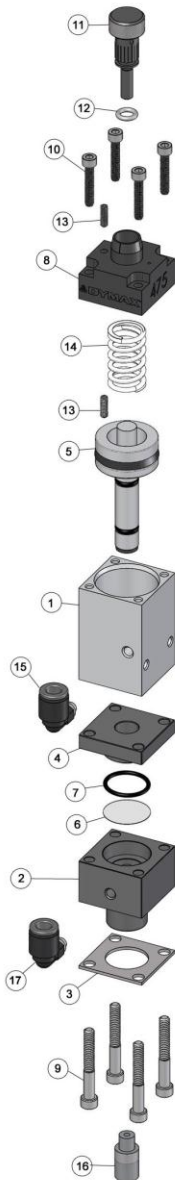

Item	Part Number	Description	Qty
1	T15312	Valve Body	1
2	T15313	Valve Seat	1
3	T15316	Spacer	1
4	T15314	Valve Body Extension	1
5	T15339	Piston	1
6	T15317	UHMWPE Diaphragm	1
7	T15323	Buna O-Ring/016	1
8	T15325	End Cap	1
9	T14216	Screw/SHCS/8-32/1.25	4
10	T14204	6-32 x 0.75" Socket Head Cap Screw, SS	4
11	T10188	Adjusting Screw	1
12	T10096	Silicone O-Ring/009	1
13	T14856	4-40 X 0.375" SOCKET HEAD SET SCREW	2
14	T14936	Spring	1
15	T11711	0.25" OD Tube, 10-32 Elbow	1
16	T11819	0.25" To Luer Lock Fitting	1
17	T11686	0.25" OD Tube x 1/8" NPT Elbow	1

# Specifications

## Specifications

Property	Specification
<b>Part Numbers</b>	<b>T15988</b> - Model 475 diaphragm valve
<b>Valve Type</b>	Pneumatic diaphragm valve, normally closed
<b>Construction Material, Wetted Parts</b>	Body           Wetted acetal Diaphragm    UHMW polyethylene
<b>Operating Air Pressure</b>	60-80 psi (4.14 – 5.51 bar)
<b>Maximum Fluid Pressure</b>	120 psi (8.27 bar)
<b>Maximum Operating Temperature</b>	120°F (49° C)
<b>Cycle Rate</b>	3,000 cycles per minute
<b>Air Input Thread</b>	10-32
<b>Fluid Inlet Thread</b>	1/8 NPT
<b>Fluid Outlet Thread</b>	1/4 - 28
<b>Free Flow Orifice</b>	0.10" (2.54 mm) diameter; other sizes available
<b>Activation</b>	Dymax DVC-345 valve controller or 3-way solenoid valve
<b>Dimensions (W x H x D)</b>	1.125" x 5.42" x 1.125" (2.86 cm x 13.77 cm x 2.86 cm)
<b>Weight</b>	5 oz (0.14 kg)
<b>Unit Warranty</b>	1 year from purchase date excluding soft seals

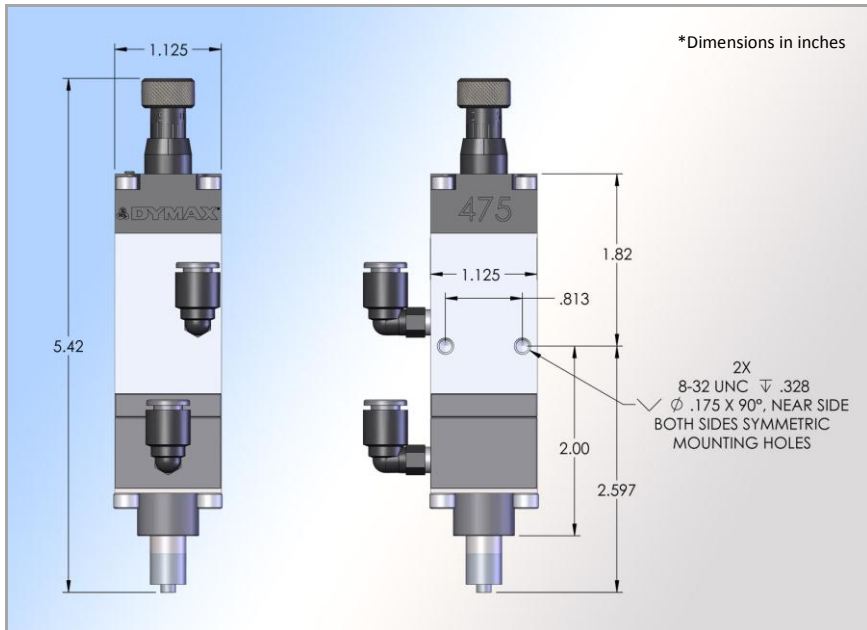
**Figure 5. Model 475 Dimensional Drawing**

## Warranty

From date of purchase, Dymax Corporation offers a one-year warranty against defects in material and workmanship on all system components (excluding soft seals) with proof of purchase and purchase date. Unauthorized repair, modification, or improper use of equipment may void your warranty benefits. The use of aftermarket replacement parts not supplied or approved by Dymax Corporation will void any effective warranties and may result in damage to the equipment.

**IMPORTANT NOTE:** DYMAX CORPORATION RESERVES THE RIGHT TO INVALIDATE ANY WARRANTIES, EXPRESSED OR IMPLIED, DUE TO ANY REPAIRS PERFORMED OR ATTEMPTED ON DYMAX EQUIPMENT WITHOUT WRITTEN AUTHORIZATION FROM DYMAX. THOSE CORRECTIVE ACTIONS LISTED ABOVE ARE LIMITED TO THIS AUTHORIZATION.

**Dymax Corporation**

860.482.1010

info@dymax.com

[www.dymax.com](http://www.dymax.com)**Dymax Oligomers &Coatings**

860.626.7006

oligomers&amp;coatings@dymax.com

[www.dymax-oc.com](http://www.dymax-oc.com)**Dymax Europe GmbH**

+49 (0) 611.962.7900

info\_de@dymax.com

[www.dymax.de](http://www.dymax.de)**Dymax UV Adhesives &  
Equipment (Shenzhen) Co Ltd**

+86.755.83485759

dymaxasia@dymax.com

[www.dymax.com.cn](http://www.dymax.com.cn)**Dymax UV Adhesives &  
Equipment (Shanghai) Co Ltd**

+86.21.37285759

dymaxasia@dymax.com

[www.dymax.com.cn](http://www.dymax.com.cn)**Dymax Asia (H.K.) Limited**

+852.2460.7038

dymaxasia@dymax.com

[www.dymax.com.cn](http://www.dymax.com.cn)**Dymax Korea LLC**

82.2.784.3434

info@dymax.kr

[www.dymax.co.kr](http://www.dymax.co.kr)

© 2012 Dymax Corporation. All rights reserved. All trademarks in this guide, except where noted, are the property of, or used under license by Dymax Corporation, U.S.A. Teflon is a registered trademark of DuPont.

Please note that most dispensing and curing system applications are unique. Dymax does not warrant the fitness of the product for the intended application. Any warranty applicable to the product, its application and use is strictly limited to that contained in Dymax's standard Conditions of Sale. Dymax recommends that any intended application be evaluated and tested by the user to insure that desired performance criteria are satisfied. Dymax is willing to assist users in their performance testing and evaluation. Data sheets are available for valve controllers or pressure pots upon request. T17350 MAN035DA 11/2/2012