

# Ram Pail Pump Selection and Setup for Dispensing Materials Packaged in Taper-Style Pails

When dispensing from 15-Liter Gray Taper Pails, Dymax recommends using a Dymax Platen and silicone wiper instead of the standard Graco wiper that comes installed on the Ram Pail Pump. Using the recommended Dymax wiper will optimize the performance of the Pail Pump by improving the seal, preventing potential chemical interaction between the material and the Wiper, and by preventing potential leak-causing damage to the Pail.

The following guidelines will help ensure a stable, consistent dispensing process with the correct Ram Pail Pump, Platen, and Wiper seal:

1. Selecting a Proper Ratio for the Ram Pail Pump
2. Converting the Standard Graco Platen to the Recommended Dymax Platen
3. Operating the Pail Pump in Proper Setting
4. Cleaning the Pail Pump with Compatible Materials

## Selecting a Proper Ratio for the Ram Pail Pump

It is important to know the viscosity of the material, the fluid line length, the fluid line ID, and the material flow rate before selecting the proper ratio Pail Pump. Once that information is known, the chart below can be used as a reference to select the correct ratio Pail Pump.

Material Viscosity	Fluid Line Length	Fluid Line ID	Flow Rate	Hose	Recommended Pump
40,000 cP	>15 ft [4.5 m], <30 ft [9 m]	0.50 in [12.7 mm]	0.10 gpm [0.37 lpm]	Teflon® SST braid	Model S20, 11:1 SST 5-Gallon Ram
62,000 cP	>15 ft [4.5 m], <30 ft [9 m]	0.375 in [9.5 mm]	0.01 gpm [0.037 lpm]	Teflon® SST Braid	Model S20, 11:1 SST 5-Gallon Ram
70,000 cP	>15 ft [4.5 m], <30 ft [9 m]	0.375 in [9.5 mm]	0.01 gpm [0.037 lpm]	Teflon® SST Braid	Model S20, 11:1 SST 5-Gallon Ram
	<15 ft [4.5 m]	0.50 in [12.7 mm]	0.05 gpm [0.189 lpm]	Teflon® SST braid	Model S20, 11:1 SST 5-Gallon Ram
140,000 cP	<15 ft [4.5 m]	0.375 in [9.5 mm]	0.01 gpm [0.037 lpm]	Teflon® SST Braid	Model S20, 11:1 SST 5-Gallon Ram
	<15 ft [4.5m]	0.50 in [12.7 mm]	0.05 gpm [0.189 lpm]	Teflon® SST braid	Model S20, 11:1 SST 5-Gallon Ram

\*Dymax recommends using a Downstream Fluid Pressure Regulator to control the flow rate between the Pail Pump and the Valve. Call Dymax for assistance if needed.

## Converting the Standard Graco Platen to the Recommended Dymax Platen

To convert the standard Graco Platen to the recommended Dymax Platen, you must disassemble the Pail Pump's Platen and replace the Wiper on the Graco Platen with the Dymax Silicone Wiper (**PN T16715**). To do so, follow the instructions below.

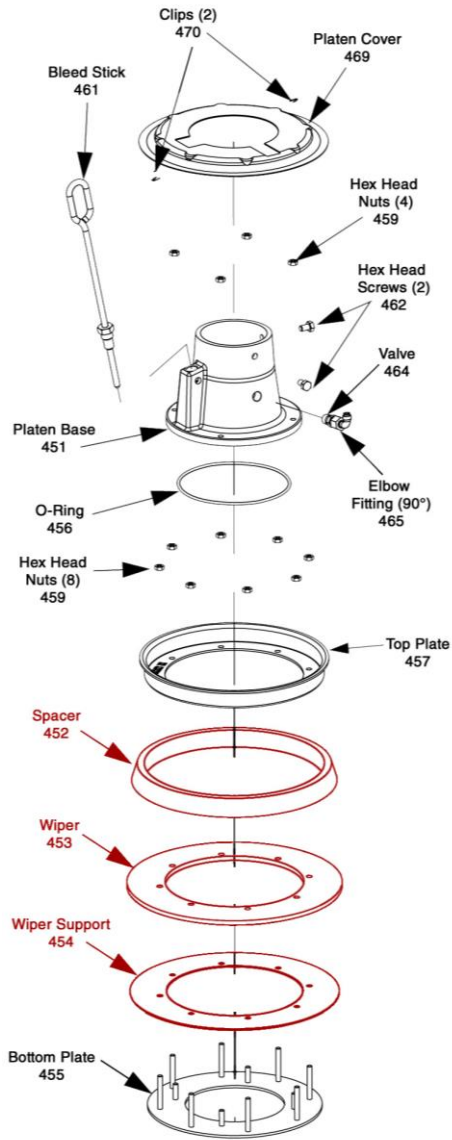

**Figure 1.** Standard Graco Platen Exploded Diagram

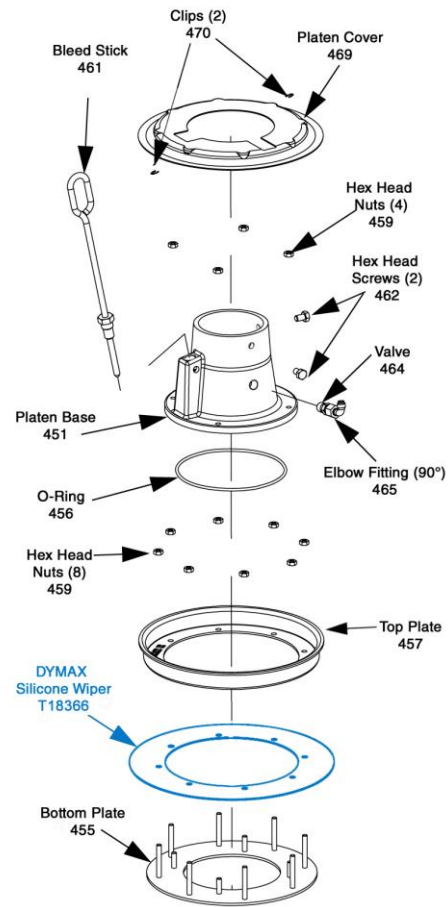

**Figure 2.** Dymax Recommended Platen Exploded Diagram

1. Loosen the Screws (462) and the 90° Elbow Fitting (465) with a hex wrench to disconnect the Platen from the device.
2. Remove the two Clips (470) from the Platen with needle nose pliers.
3. Remove the Bleed Stick (461) and Platen Cover (469).
4. Remove the eight Nuts (459) on the Wiper Assembly.
5. Separate the Top Plate (457), Spacer (452), Wiper (453), Wiper Support (454), and Bottom Plate (455).
6. Discard the Spacer, Wiper, and Wiper Support. These parts are replaced with the Dymax Silicone Wiper (T18366).
7. Place the Dymax Silicon Wiper (T18366) and Top Plate (457) on the Bottom Plate (455).
8. Replace and tighten the eight Nuts (459) on the Wiper Assembly.
9. Place the Platen Cover on the Platen and the reinstall the two Clips (470).
10. Reinstall the Platen on the device and tighten the Screws (462) and 90° Elbow Fitting (465).

## **Operating the Ram Pail Pump in Proper Setting**

Use ram pressure to install the Platen into the Pail until the Platen Wiper contacts the material. Material will be visible at the Platen Bleed Port when the Ram is in starting position. Once the Platen is in starting position, the ram pressure should be set back to 0 psi.

**NOTE:** If the ram pressure is used, the material may be forced by the Wiper seal and dispensing may be affected.

See the appropriate Graco manual for Ram Pail Pump operation instructions.

## **Cleaning the Ram Pail Pump with Compatible Materials**

Dymax recommends using technical grade 99% Isopropyl Alcohol (IPA) to clean the Silicone Wiper. For cleaning instructions for all other Pail Pump parts, please refer to Graco documentation.



© 2012-2018 Dymax Corporation. All rights reserved. All trademarks in this guide, except where noted, are the property of, or used under license by Dymax Corporation, U.S.A. Teflon is a registered trademark of Dupont.

The data contained in this bulletin is of a general nature and is based on laboratory test conditions. Dymax Europe GmbH does not warrant the data contained in this bulletin. Any warranty applicable to products, its application and use is strictly limited to that contained in Dymax Europe GmbH's General Terms and Conditions of Sale published on our homepage [http://www.dymax.com/de/pdf/dymax\\_europe\\_general\\_terms\\_and\\_conditions\\_of\\_sale.pdf](http://www.dymax.com/de/pdf/dymax_europe_general_terms_and_conditions_of_sale.pdf). Dymax Europe GmbH does not assume any responsibility for test or performance results obtained by users. It is the user's responsibility to determine the suitability for the product application and purposes and the suitability for use in the user's intended manufacturing apparatus and methods. The user should adopt such precautions and use guidelines as may be reasonably advisable or necessary for the protection of property and persons. Nothing in this bulletin shall act as a representation that the product use or application will not infringe a patent owned by someone other than Dymax Corporation or act as a grant of license under any Dymax Corporation Patent. Dymax Europe GmbH recommends that each user adequately test its proposed use and application of the products before actual repetitive use, using the data contained in this bulletin as a general guide.

TB071EU 4/16/2018

**Dymax Corporation**  
+1.860.482.1010 | [info@dymax.com](mailto:info@dymax.com) | [www.dymax.com](http://www.dymax.com)

**Dymax Europe GmbH**  
+49 (0) 611.962.7900 | [info\\_de@dymax.com](mailto:info_de@dymax.com) | [www.dymax.de](http://www.dymax.de)

**Dymax Engineering Adhesives Ireland Ltd.**  
+353 21.237.3016 | [info\\_ie@dymax.com](mailto:info_ie@dymax.com) | [www.dymax.ie](http://www.dymax.ie)

**Dymax Oligomers & Coatings**  
+1.860.626.7006 | [info\\_oc@dymax.com](mailto:info_oc@dymax.com) | [www.dymax-oc.com](http://www.dymax-oc.com)

**Dymax UV Adhesives & Equipment (Shanghai) Co. Ltd.**  
+86.21.37285759 | [dymaxasia@dymax.com](mailto:dymaxasia@dymax.com) | [www.dymax.com.cn](http://www.dymax.com.cn)

**Dymax UV Adhesives & Equipment (Shenzhen) Co. Ltd.**  
+86.755.83485759 | [dymaxasia@dymax.com](mailto:dymaxasia@dymax.com) | [www.dymax.com.cn](http://www.dymax.com.cn)

**Dymax Asia (H.K.) Limited**  
+852.2460.7038 | [dymaxasia@dymax.com](mailto:dymaxasia@dymax.com) | [www.dymax.com.cn](http://www.dymax.com.cn)

**Dymax Asia Pacific Pte. Ltd.**  
+65.6752.2887 | [info\\_ap@dymax.com](mailto:info_ap@dymax.com) | [www.dymax-ap.com](http://www.dymax-ap.com)

**Dymax Korea LLC**  
+82.2.784.3434 | [info\\_kr@dymax.com](mailto:info_kr@dymax.com) | [www.dymax.com/kr](http://www.dymax.com/kr)