

# SD-100

## Digital Syringe Dispenser User Guide

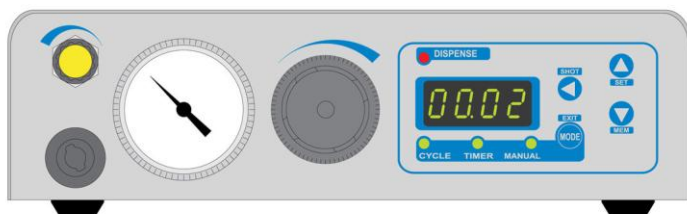

## About Dymax

### **UV/Visible light-curable adhesives. Systems for light curing, fluid dispensing, and fluid packaging.**

Dymax manufactures industrial adhesives, light-curable adhesives, epoxy resins, cyanoacrylates, and activator-cured adhesives. We also manufacture a complete line of manual fluid dispensing systems, automatic fluid dispensing systems, and light-curing systems. Light-curing systems include LED light sources, spot, flood, and conveyor systems designed for compatibility and high performance with Dymax adhesives.

Dymax adhesives and light-curing systems optimize the speed of automated assembly, allow for 100% in-line inspection, and increase throughput. System designs enable stand-alone configuration or integration into your existing assembly line.

Please note that most dispensing and curing system applications are unique. Dymax does not warrant the fitness of the product for the intended application. Any warranty applicable to the product, its application and use is strictly limited to that contained in the Dymax standard Conditions of Sale. Dymax recommends that any intended application be evaluated and tested by the user to insure that desired performance criteria are satisfied. Dymax is willing to assist users in their performance testing and evaluation. Data sheets are available for valve controllers or pressure pots upon request.

# Contents

<b>Contents</b> .....	<b>3</b>
<b>Introduction</b> .....	<b>4</b>
Where to Get Help .....	4
<b>Safety</b> .....	<b>5</b>
General Safety Considerations .....	5
Specific Safety Considerations .....	5
<b>Product Overview</b> .....	<b>6</b>
Description of the SD-100 Syringe Dispenser.....	6
Special Features and Benefits of the SD-100 .....	6
Front Control Panel .....	8
Rear Panel .....	10
<b>Assembly and Setup</b> .....	<b>10</b>
Unpacking and Inspecting Your Shipment .....	10
Parts Included in the SD-100 Syringe Dispenser .....	11
System Interconnect .....	11
<b>Operating the System</b> .....	<b>12</b>
Operation .....	12
Saving Dispense to Memory.....	13
Loading from Memory .....	14
Setting the Decimal Point.....	15
Auto-Purge Function .....	15
<b>Troubleshooting</b> .....	<b>16</b>
<b>Spare Parts and Accessories</b> .....	<b>17</b>
Options/Accessories.....	17
<b>Specifications</b> .....	<b>18</b>
Specifications .....	18
<b>Warranty</b> .....	<b>19</b>
<b>Index</b> .....	<b>19</b>

# Introduction

This guide describes how to assemble, use, and maintain the Dymax SD-100 syringe dispensing system safely and efficiently.

## Intended Audience

This user guide was prepared for experienced process engineers, maintenance technicians, and manufacturing personnel. If you are new to pneumatically operated fluid dispensing equipment and do not understand the instructions, contact Dymax Application Engineering to answer your questions before using the equipment.

## Where to Get Help

Additional resources are available to ensure a trouble-free experience with our products:

- » Detailed product information on [www.dymax.com](http://www.dymax.com).
- » Customer Support and Application Engineering teams are available in the United States, Monday through Friday, from 8:00 a.m. to 5:30 p.m. Eastern Standard Time. You can also email Dymax at [info@dymax.com](mailto:info@dymax.com). Please see the back cover of this manual for additional Dymax locations.
- » Dymax adhesive Product Data Sheets (PDS) on our website.
- » Material Safety Data Sheets (MSDS) provided with shipments of Dymax adhesives.

# Safety



***WARNING!*** If you use this fluid dispensing equipment without first reading and understanding the information in this guide, personal injury can result from the uncontrolled release of high-pressure gas, injection, or exposure to chemicals. To reduce the risk of injury, read and understand this guide before assembling and using Dymax fluid dispensing equipment.

## General Safety Considerations

All users of Dymax fluid dispensing equipment should read and understand this user guide before assembling and using the equipment.

To learn about the safe handling and use of dispensing fluids, obtain and read the MSDS for each fluid before using it. Dymax includes an MSDS with each adhesive sold. MSDS for Dymax products can be requested through the Dymax website.

## Specific Safety Considerations

### Using Safe Operating Pressures

Pressurizing the components in the dispensing system beyond the maximum recommended pressure can result in the rupturing of components and serious personal injury. To minimize the risk of rupturing components and injury, do not exceed the maximum operating pressure of the components in your fluid dispensing system (see system specifications on page 18).

### Preventing Injection Injury

Discharging fluids or compressed air with a dispensing tip against your skin can cause very serious injection injury. To minimize the risk of injection injury, do not place the dispensing tip in contact with your skin.

# Product Overview

## Description of the SD-100 Syringe Dispenser

The SD-100 digital liquid dispenser, with its versatile design, is perfectly suited for a wide variety of dispensing applications from microdot deposits to large potting and filling. Suitable for all types of fluids, it includes a suck-back feature to ensure low viscosity liquids do not drip from the dispense tip.

The SD-100 provides a micro-controlled timer programmable from 0.01 to 9999 seconds.

Included hoses, fittings, and dispense tips make the unit ready to use right out of the box.

## Special Features and Benefits of the SD-100

Feature	Benefit
Adjustable vacuum suck-back	Clean, drip-free cycle shut-off
Digital timer with a range of 0.01 to 9999 seconds	Precision control over fluid dispense
Delivers micro-shots, beads, or fills	Timed or manual mode with adjustable time and pressure settings; includes the ability to save a set time in memory
9 Programmable memory slots	Memory saves system settings for future cycles
Activation by foot pedal or external signal; optional finger switch available	Manual or system-integrated operation
Adjustable air pressure fluid regulator	Adjust and set the proper air pressure setting for very thin fluids to very thick fluids

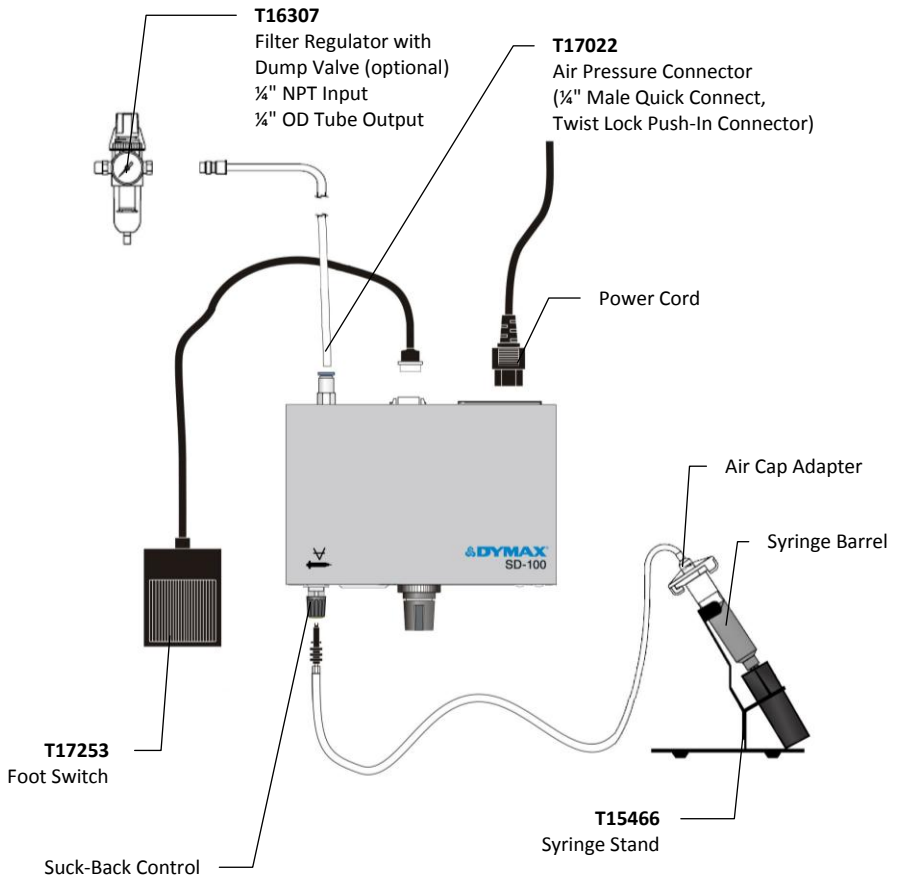

**Figure 1. Main Components of the SD-100 Syringe Dispenser**

## Front Control Panel

The front control panel of the SD-100 (Figure 2) includes:

- » **Suck Back Control** — Keeps a steady pull of air pressure in the syringe when not dispensing. This will help if material is leaking from the syringe.
- » **Pressure Gauge** — Shows the amount of pressure being applied to the syringe, via the aircap, to dispense.
- » **Air Pressure Regulator** — Adjusts the amount of pressure being used to dispense. In order to reach a desired pressure level, first pull the knob out to unlock it so it will rotate. Turn the knob counter-clockwise to a point below the desired pressure, and then turn the dial clockwise to reach the desired pressure.
- » **Barrel/Valve Air Cap Outlet** — Air outlet where valve or barrel can be hooked up.
- » **Digital Display** — Displays information pertaining to the programming and use of the unit.
- » **▲/SET** — Used as an up scroll key and to begin programming a mode.
- » **▼/MEM** — Used as a down scroll key and to save / recall a program.
- » **◀/SHOT** — Used as a left scroll key and to begin dispensing.
- » **MODE/EXIT** — Used to toggle between dispensing modes and to exit some functions. The SD-100 has the following operation modes:

**MANUAL** — In this mode the unit will dispense as long as the foot pedal or SHOT button is pressed.

**TIMER** — The unit will dispense for a set amount of time regardless of how long the foot pedal or shot button is pressed.

**CYCLE** — The unit will dispense and wait for a specified amount of time before dispensing again. It will cycle continuously until the EXIT button is pressed.

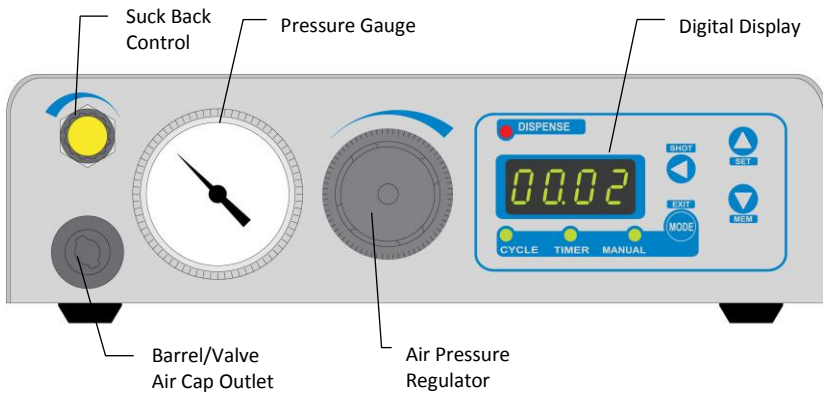
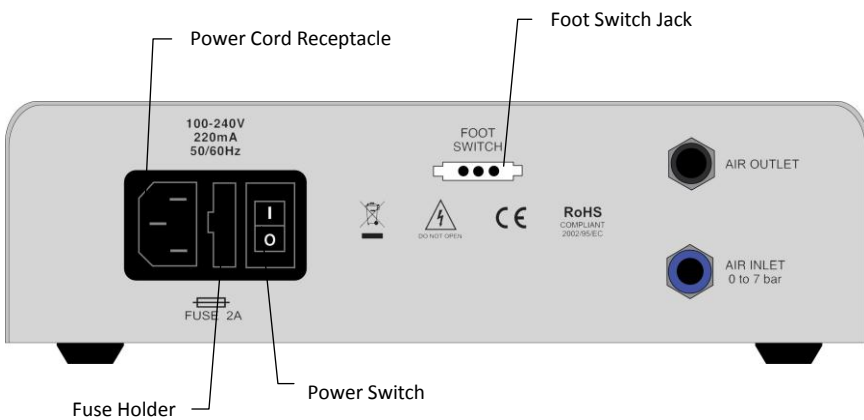

**Figure 2. SD-100 Front Panel****Figure 3. Rear Panel**

## Rear Panel

The rear panel of the SD-100 (Figure 3) includes:

- » **Power Cord Receptacle** — Connection point for the power cord.
- » **Fuse Holder**
- » **Power Switch**
- » **Foot Switch Jack** — Connection point for the foot switch. Pressing the foot switch starts a dispense cycle. In timed operation, pressing and releasing the foot switch dispenses fluid for the length of time displayed on the digital display. In manual operation, pressing and holding the foot switch dispenses fluid until the switch is released.
- » **Air Outlet Port** — Connection point for air out.
- » **Air Inlet Port**— Connection point for air in.

# Assembly and Setup

## Unpacking and Inspecting Your Shipment

When your SD-100 syringe dispensing system arrives, inspect the box for damage and notify the shipper of box damage immediately.

Open the box and check for equipment damage. If parts are damaged, notify the shipper and submit a claim for the damaged parts. Contact Dymax so that new parts can be shipped to you immediately.

Check that the parts included in your order match those listed below. If parts are missing, contact your local Dymax representative or Dymax Customer Support to resolve the problem.

## Parts Included in the SD-100 Syringe Dispenser

- SD-100 digital syringe dispense controller
- Air cap adapter, 1 each for 3, 5, 10, and 30/55 mL barrels
- Air hose and fittings
- Foot switch
- Power cord
  - » T17241 – Type G power cord
  - » T17242 – No power cord
- Syringe stand
- Start-up kit containing assorted dispense tips
- Printed user guide

## System Interconnect

1. Connect air hose to filtered compressed air 70 - 100 psi (5-7 bar) and connect fitting to the dispenser.
2. Insert the foot switch plug.
3. Insert and twist the male quick connect into the dispenser.
4. Insert the power cord's female plug into the dispenser and insert the male plug into a grounded outlet.
5. Attach the syringe barrel (with tip cap on the syringe barrel) with the material to be dispensed. Lock the barrel to the air cap assembly as shown in Figure 4.

**Figure 4. Barrel and Air Cap Assembly Lock Procedure**

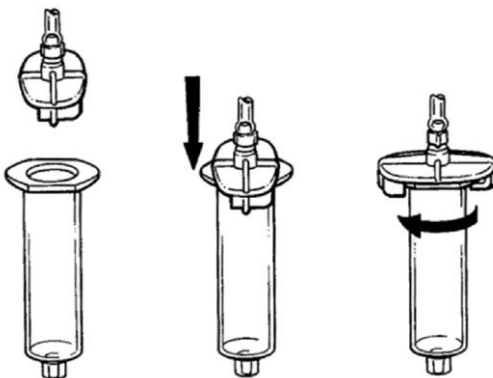

# Operating the System

## Operation

### Manual Mode

Manual mode allows the user to dispense for an unlimited amount of time by either pressing down on the supplied foot pedal or pushing the SHOT button on the front of the SD-100 unit. The material will continue to dispense for as long as the user is pushing down on the foot pedal or pressing the SHOT button. As soon as either of these are released, the dispensing will stop.

The unit will also count the amount of time you are dispensing during a cycle which may be helpful in determining a time to be used when programming the timer mode. If you need to adjust the decimal point to allow for the timer to show a higher or smaller value, press the SET button then use the ▲ and ▼ to adjust the position.

1. Press the MODE button to cycle to Manual Mode.
2. Press the SHOT button or the foot pedal to start dispense. Release either to stop dispense.

### Timer Mode

The Timer Mode allows the user to dispense for a set period of time despite how long the foot pedal is pressed.

For example: If you would like to set the dispenser to dispense for 1 second, follow the instructions below.

1. Press the MODE button until the timer mode is selected.
2. Press the SET button. The first digit on the right side of the display will start blinking.
3. Press the ◀ button twice. The third digit from the right on the digital display should be blinking.
4. Press the ▲ button once to increase the value of this digit. To adjust the decimal refer to page 15.
5. Press Exit/Mode to save as current setting.

To use timer mode, you can either press the SHOT button on the front panel of the SD-100 unit or press down on the foot pedal.

## Cycle Mode

Cycle mode allows the user to create a repeating cycle of dispensing. This is programmed by setting a wait time between dispensing. This mode is reliant on the previous setting that was made in timer mode to determine the length of dispensing during the cycle.

For example: If you would like to dispense for 1 second, then wait for 5 seconds, and cycle these times over again, you would need to have already set your timer mode for 1 second (see previous page for these instructions). To set the 5 second wait time in your cycle, follow the directions below.

1. Press the MODE button until the cycle mode is selected.
2. Press the SET button. The first digit on the right side of the digital display will start blinking.
3. Press the ◀ button two times. The third digit from the right should be blinking.
4. Press the ▲ button five times. The display should now show a 5 second wait time. (To adjust the decimal refer to page 15)
5. Press Exit/Mode to save as current setting.

To use the cycle mode, press the SHOT button on the SD-100 to activate the cycle. To deactivate the cycle, press the EXIT button.

## Saving Dispense to Memory

The SD-100 has the storage capacity for up to 9 programs that can be saved to its memory for future recall. The memory will always save your current settings for the particular mode you are in.

For example: If you want to save your current timer mode setting to Program 9, you will first need to select timer mode then proceed with saving. You can also save your cycle mode settings to Program 9 by following the same procedure.

To save your current settings to memory address 9, follow the instructions below.

1. While in timer or cycle mode, change to the mode you would like to save then press and hold the MEM (Memory) key for 2 seconds until the unit beeps.
2. The display will show Ld 1 (Load from Memory #1).
3. Press the MEM key again to change from Ld 1 to Sv 1 (Save to Memory #1).
4. Press the ▲ key 8 times to get to memory address 9.
5. Press the EXIT key to complete the save.

To save your current cycle mode settings, switch the mode to cycle and then continue with the above procedure.

## Loading from Memory

After saving your cycle and timer mode settings to the SD-100 memory, you can recall them to be used again. Both the cycle mode and timer mode need to be loaded separately by switching to the mode you would like to load.

For example: To load the cycle time that was saved in Memory 9 on the previous page, follow the steps below.

1. Switch to cycle mode then press and hold the MEM (Memory) key for 2 seconds until the unit beeps.
2. The display will show Ld 1 (Load from Memory #1).
3. Press the ▲ key 8 times to get to memory address 9.
4. Press the EXIT button to complete the load. Program 9 cycle mode settings are now in effect. The display should show 5 seconds.

To load the timer mode settings, switch to timer mode then follow the same directions.

## Setting the Decimal Point

The decimal point is normally set at a default place between the second and third digits on the display. This can be changed to allow for a longer or shorter dispense time. To change the decimal place position, press the SET button then the ◀ button 4 times. This will make the decimal point blink. When the decimal point is blinking, you can then press the ▲ or ▼ buttons to adjust its position.

## Auto-Purge Function

The auto-purge function is used when a material is being dispensed that may cure in the dispensing needle if left sitting for long periods of time. Before auto purging your material, be sure to read over the material MSDS for any precautions that may need to be taken. Also be sure that you have a proper storage container for the purged material.

In order to setup auto-purge on the SD-100 dispenser, the user must configure both the time it needs to dispense (dispense time) and the time it pauses before dispensing again (wait time). The total time will be the time it takes the dispenser to complete the whole cycle.

$$\text{Cycle Time} = \text{Dispense Time} + \text{Wait Time}$$

For example, let's say you wanted to auto-purge one second worth of material every five seconds for a total time of six seconds. What you need to do is:

- » Set the dispense time to 1 second.
- » Set the wait time to 5 seconds.

# Troubleshooting

If you are experiencing a problem with your SD-100 Syringe Dispenser, please look through the following troubleshooting section. If your unit is still not working properly after reviewing the troubleshooting recommendations, please contact Dymax Application Engineering for assistance.

***IMPORTANT!*** Before dispensing always check to make sure that tubing and connections are not damaged or loose. Always replace damaged parts immediately.

**Table 2. Troubleshooting Chart for SD-100 Controller**

Problem	Possible Cause	Corrective Action
Unit will not dispense	Clogged dispensing tip	Replace the clogged tip with a new dispensing tip
	Unit is not properly connected to air or power	Check that all electrical and air utilities are operating and connected
	Air cap line is clamped shut	Make sure that the tubing clamp is not on the air cap line
	Syringe barrel is not full	Add material to the syringe barrel or replace it with a new filled barrel
	Foot pedal is not connected	Fully insert the foot pedal into connector on rear of system
Continued flow, bleeding, or dripping after the dispenser is shut off	Not enough vacuum	Increase the amount of vacuum you are using
Air or material is being pulled up into the tubing	Vacuum is too high	Decrease the amount of vacuum you are using
No flow	Not enough air pressure	Increase the air pressure or use a larger orifice dispense tip



# Spare Parts and Accessories

## Options/Accessories

Item	Part Number
<b>Air Cap Assemblies</b>	
Plastic, 3 mL	T17600
Plastic, 5 mL	T17603
Plastic, 10 mL	T17602
Plastic, 30/55 mL	T17601
<b>Air Filters</b>	
Filter Regulator with Dump Valve	T16307
<b>Foot Switches</b>	
Replacement Foot Switch	T17253
<b>Power Cords</b>	
Power Cord, North American (Type B, 120V)	T17021
Power Cord, China/Europe (Type G, 220-240V)	T17247
Power Cord, International (No Plug End Installed)	T17248
<b>Stands</b>	
Syringe Stand	T15466
3-Position Suspended Syringe Stand	T15505
<b>Syringes/Pistons</b>	
Syringe, Clear, 3 mL / Piston, Gray, 3 mL	T15652 / T15656
Syringe, Clear, 5 mL / Piston, Gray, 5 mL	T11169 / T11171
Syringe, Clear, 10 mL / Piston, Gray, 10 mL	T11172 / T11174
Syringe, Clear, 30 mL / Piston, Gray, 30 mL	T11176 / T11181
<b>Tip Caps, Dispense Tips, &amp; Connectors</b>	
Air Pressure Connector	T17022
Syringe Tip Cap	T11182
Dispense Tip Kit (assorted)	T16972

# Specifications

## Specifications

Property	Specification
<b>Part Numbers</b>	<b>T17242</b> International Version (no power cord)
	<b>T17241</b> Asian Version (type G power cord)
<b>Power Requirements</b>	Input Voltage: 90 - 260 VAC
	Internal Voltage: 24 VDC
<b>Air Requirements</b>	Input 70 - 100 psi [5-7 bar]
	Output 1 - 100 psi [0.1-7 bar]
<b>Dispense Time</b>	0.01- 9999 seconds
<b>Cycle Speed</b>	600+ /minute
<b>Dimensions (W x D x H)</b>	8.625" x 8.50" x 2.625" [22 cm x 21 cm x 6.7 cm]
<b>Weight</b>	2.2 lbs (1 kg)
<b>Unit Warranty</b>	2 years from purchase date
<b>Certifications</b>	CE, RoHs 2002/95/EC

# Warranty

From date of purchase, Dymax Corporation offers a two-year warranty against defects in material and workmanship on all system components (excluding consumables) with proof of purchase and purchase date. Unauthorized repair, modification, or improper use of equipment may void your warranty benefits. The use of aftermarket replacement parts not supplied or approved by Dymax Corporation will void any effective warranties and may result in damage to the equipment.

**IMPORTANT NOTE:** DYMAX CORPORATION RESERVES THE RIGHT TO INVALIDATE ANY WARRANTIES, EXPRESSED OR IMPLIED, DUE TO ANY REPAIRS PERFORMED OR ATTEMPTED ON DYMAX EQUIPMENT WITHOUT WRITTEN AUTHORIZATION FROM DYMAX. THOSE CORRECTIVE ACTIONS LISTED ABOVE ARE LIMITED TO THIS AUTHORIZATION.

# Index

- Air Connections, 7, 11
- Assembly and Setup, 10
- Auto-Purge Function, 15
- Back Panel Controls, 10
- Components, 7
- Error Codes and Troubleshooting, 16
- Features and Benefits, 6, 10
- Fluid Connections, 11
- Front Panel Controls, 8
- Memory
  - Loading from Memory, 14
  - Saving to Memory, 13
- Operation Modes
  - Cycle Mode, 13
  - Manual Mode, 12
  - Timer Mode, 12
- Optional Equipment, 17
- Parts Included, 11
- Product Overview, 6
- Purging the System, 15
- Safety, 5
  - Preventing Injection Injury, 5
  - Using Safe Operating Pressures, 5
- Setting the Decimal Point, 15
- Spare Parts and Accessories, 17
- Specifications, 18
- Troubleshooting, 16
- Unpacking, 10
- Warranty, 19

**Dymax Corporation**

860.482.1010

info@dymax.com

[www.dymax.com](http://www.dymax.com)**Dymax Oligomers &Coatings**

860.626.7006

oligomers&amp;coatings@dymax.com

[www.dymax-oc.com](http://www.dymax-oc.com)**Dymax Europe GmbH**

+49 (0) 611.962.7900

info\_de@dymax.com

[www.dymax.de](http://www.dymax.de)**Dymax UV Adhesives &  
Equipment (Shenzhen) Co Ltd**

+86.755.83485759

dymaxasia@dymax.com

[www.dymax.com.cn](http://www.dymax.com.cn)**Dymax UV Adhesives &  
Equipment (Shanghai) Co Ltd**

+86.21.37285759

dymaxasia@dymax.com

[www.dymax.com.cn](http://www.dymax.com.cn)**Dymax Asia (H.K.) Limited**

+852.2460.7038

dymaxasia@dymax.com

[www.dymax.com.cn](http://www.dymax.com.cn)**Dymax Korea LLC**

82.2.784.3434

info@dymax.kr

[www.dymax.co.kr](http://www.dymax.co.kr)

© 2012 Dymax Corporation. All rights reserved. All trademarks in this guide, except where noted, are the property of, or used under license by Dymax Corporation, U.S.A. Please note that most dispensing and curing system applications are unique. Dymax does not warrant the fitness of the product for the intended application. Any warranty applicable to the product, its application and use is strictly limited to that contained in Dymax's standard Conditions of Sale. Dymax recommends that any intended application be evaluated and tested by the user to insure that desired performance criteria are satisfied. Dymax is willing to assist users in their performance testing and evaluation. Data sheets are available for valve controllers or pressure pots upon request.

T17308 MAN043DA 12/26/2012