

Eco-SPRAY

Precision Micro-Spraying System

- Constant amount/area
- Consistent spray pattern
- Uniform coating
- Little overspray/high edge definition
- Defined volume per rotation
- High chemical resistance
- High bracing
- Controllable round spray
- Variety of spray volumes, from dot to endless spraying
- Independent regulation of media flow
- High transfer efficiency rate and atomizer air
- Spraying of defined quantity
- Optional heating
- Viscosity independent spraying
- System is low maintenance and easy to clean
- Adjustable spray area
- Pressure-tight without valve
- Compatible with a wide range of low to high viscosity materials

The eco-SPRAY by ViscoTec is a precise, micro-spray system suitable for a wide variety of applications. Its combination of a reliable, endless piston and a low-flow spray chamber provides precise spraying of low- to high-viscosity fluids – with high edge definition.

This dispenser provides volumetric spray application based on the endless piston principle. The base of this micro-spray technology is ViscoTec's proven rotor/stator technology. Due to the defined rotary motion of the rotor, the material in the stator is volumetrically replaced and conveyance is created. Thus, a determined amount of material is process controlled and directed to the special low flow spray chamber. The precise nebulization and spraying can take place continuously or punctually. The revolutionary combination of the endless piston principle and the low-flow spraying chamber allows precise spraying of low to highly viscous materials with high edge definition and lowest possible over-spray.

Specifications

Specifications	
Part Number	T18559
Dimension	Length 228 mm, ø 35 mm
Material In-Feed	1/8" cylindrical whithworth pipe thread DIN/ISO 228
Parts with Medium Contact	HD-POM/Stainless Steel/PEEK
Min. Operating Pressure	0 bar, self-leveling fluid
Max. Operating Pressure	0 to 6 bar input pressure, non-self-leveling fluid
Intrinsic Tightness*	Approx. 2 bar (reference medium approx. 10 mPas at 20° C)
Seals	High-molecular PE, VisChem
Motor	18 to 24 V/DC, incremental encoder, planetary gears
Switching Frequency:	Over 100 cycles/min
Operating Conditions	+10° C to +40° C, air pressure 1 bar
Medium Temperature	+10° C to +40° C (optional with heating)
Medium Viscosity	Low- to high-viscosity media
Min. Dosing Quantity	50 µl
Volume Flow**	0.5 to 6.0 ml/min
Diameter:	0.2 mm, 0.3 mm, 0.5 mm
Spraying Accuracy***	Amount of spraying ± 1%
Repeatability	> 99%
Atomizer Air	0.1 to 6 bar
Atomizer Supply	Hose connector external diameter 4 mm (connection to the process M5)
Spray Image	Round spray (adjustable)
Spray Angle	15 to 30°
Accessories	T18560 ViscoTec Valve Mounting Fixture



* Max. dosing pressure and intrinsic tightness will decrease in direct proportion to a decrease in viscosity and increase in direct proportion to an increase in viscosity. Please contact Dymax Application Engineering for more information.

** Volume flow depends on viscosity and primary pressure.

***Volumetric dosing as absolute deviation in relation to one dispenser revolution. Depends on the viscosity of the material being dispensed.

Figure 1. eco-SPRAY Dimensions

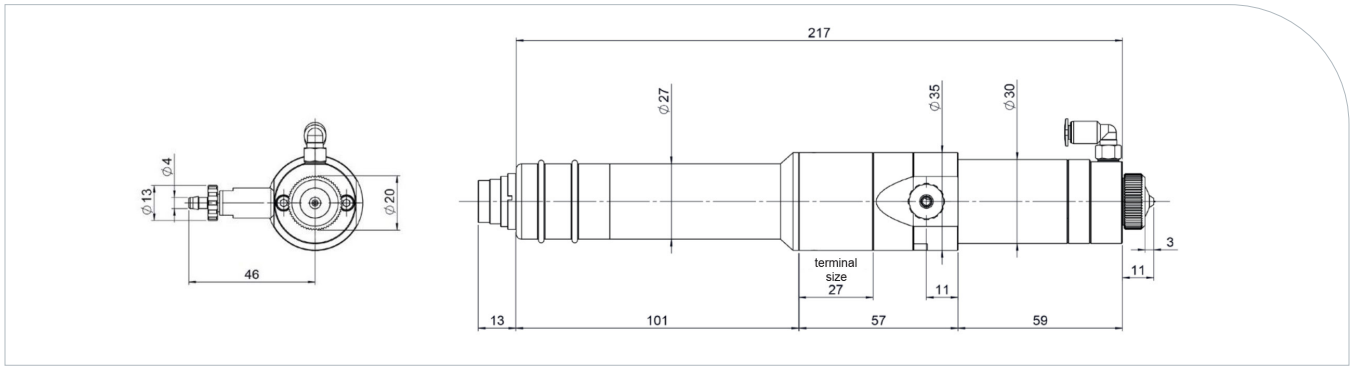

Figure 2. Comparison of Standard Spray Equipment and eco-SPRAY

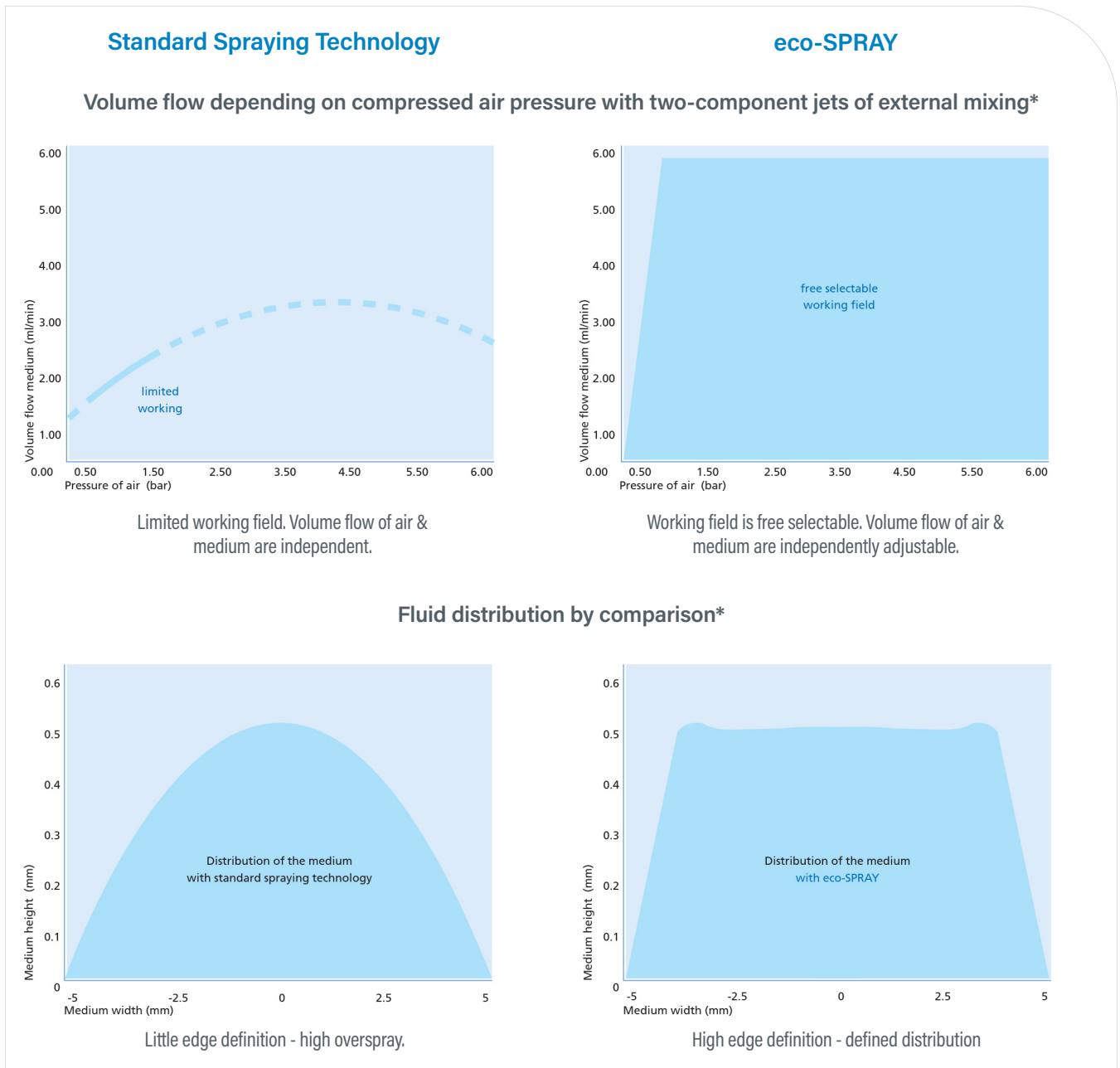
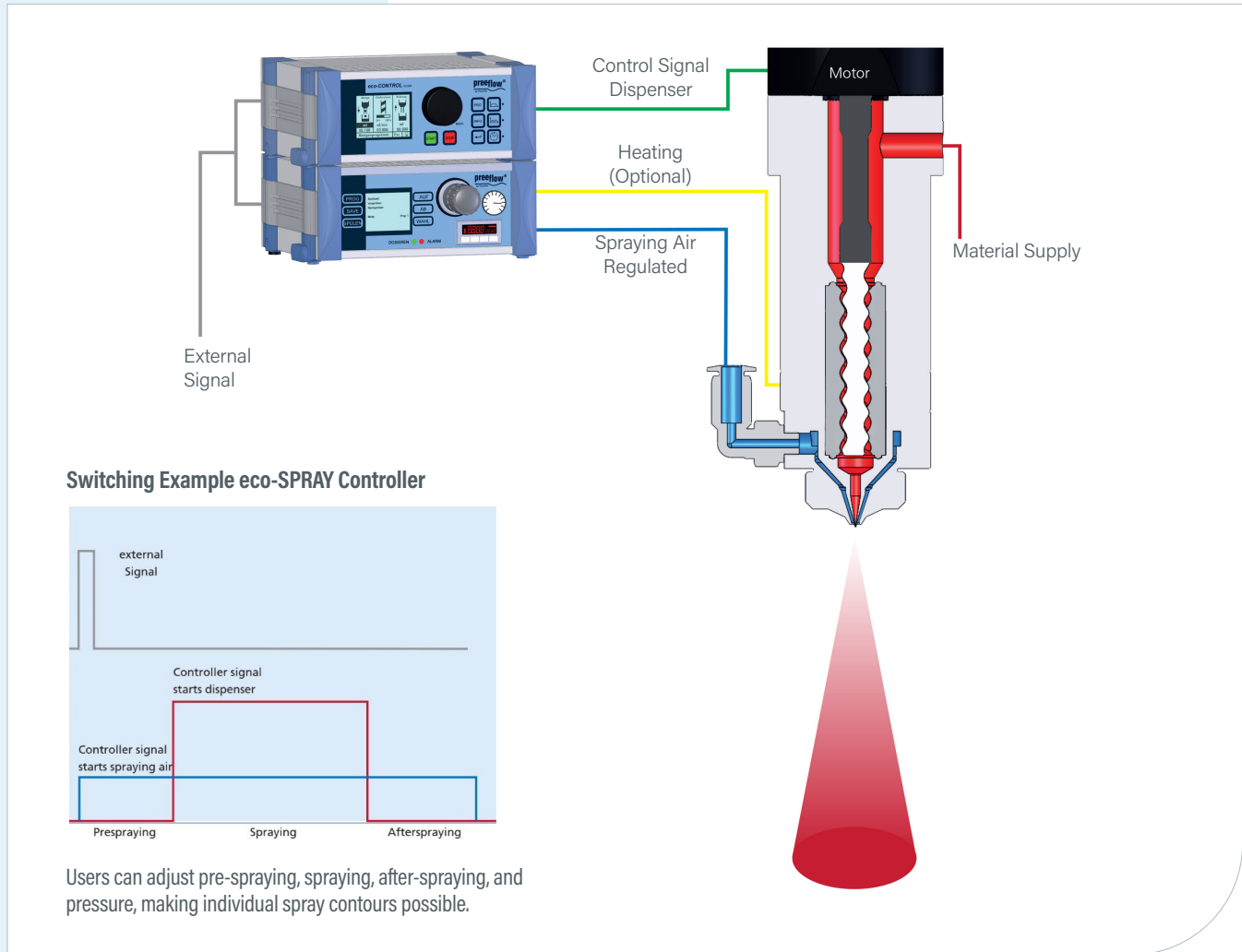

Figure 3. eco-SPRAY System



www.dymax.com

Americas

USA | +1.860.482.1010 | info@dymax.com

Europe

Germany | +49 611.962.7900 | info_de@dymax.com
 Ireland | +353 21.237.3016 | info_ie@dymax.com

Asia

Singapore | +65.67522887 | info_ap@dymax.com
 Shanghai | +86.21.37285759 | dymaxasia@dymax.com
 Shenzhen | +86.755.83485759 | dymaxasia@dymax.com
 Hong Kong | +852.2460.7038 | dymaxasia@dymax.com
 Korea | +82.31.608.3434 | info_kr@dymax.com