

Eco-SPRAY

Precision Micro-Spraying System

- Constant amount/area
- Consistent spray pattern
- Uniform coating
- Little overspray/high edge definition
- Defined volume per rotation
- High chemical resistance
- High bracing
- Controllable round spray
- Variety of spray volumes, from dot to endless spraying
- Independent regulation of media flow
- High transfer efficiency rate and atomizer air
- Spraying of defined quantity
- Optional heating
- Viscosity independent spraying
- System is low maintenance and easy to clean
- Adjustable spray area
- Pressure-tight without valve
- Compatible with a wide range of low to high viscosity materials

The eco-SPRAY by ViscoTec is a precise, micro-spray system suitable for a wide variety of applications. Its combination of a reliable, endless piston and a low-flow spray chamber provides precise spraying of low- to high-viscosity fluids – with high edge definition.

This dispenser provides volumetric spray application based on the endless piston principle. The base of this micro-spray technology is ViscoTec's proven rotor/stator technology. Due to the defined rotary motion of the rotor, the material in the stator is volumetrically replaced and conveyance is created. Thus, a determined amount of material is process controlled and directed to the special low flow spray chamber. The precise nebulization and spraying can take place continuously or punctually. The revolutionary combination of the endless piston principle and the low-flow spraying chamber allows precise spraying of low to highly viscous materials with high edge definition and lowest possible over-spray.

Specifications

| Specifications | |
|---------------------------|--|
| Part Number | T18559 |
| Dimension | Length 228 mm, ø 35 mm |
| Material In-Feed | 1/8" cylindrical whitworth pipe thread DIN/ISO 228 |
| Parts with Medium Contact | HD-POM/Stainless Steel/PEEK |
| Min. Operating Pressure | 0 bar, self-leveling fluid |
| Max. Operating Pressure | 0 to 6 bar input pressure, non-self-leveling fluid |
| Intrinsic Tightness* | Approx. 2 bar (reference medium approx. 10 mPas at 20° C) |
| Seals | High-molecular PE, VisChem |
| Motor | 18 to 24 V/DC, incremental encoder, planetary gears |
| Switching Frequency: | Over 100 cycles/min |
| Operating Conditions | +10° C to +40° C, air pressure 1 bar |
| Medium Temperature | +10° C to +40° C (optional with heating) |
| Medium Viscosity | Low- to high-viscosity media |
| Min. Dosing Quantity | 50 µl |
| Volume Flow** | 0.5 to 6.0 ml/min |
| Diameter: | 0.2 mm, 0.3 mm, 0.5 mm |
| Spraying Accuracy*** | Amount of spraying ± 1% |
| Repeatability | > 99% |
| Atomizer Air | 0.1 to 6 bar |
| Atomizer Supply | Hose connector external diameter 4 mm (connection to the process M5) |
| Spray Image | Round spray (adjustable) |
| Spray Angle | 15 to 30° |
| Accessories | T18560 ViscoTec Valve Mounting Fixture |



* Max. dosing pressure and intrinsic tightness will decrease in direct proportion to a decrease in viscosity and increase in direct proportion to an increase in viscosity. Please contact Dymax Application Engineering for more information.

** Volume flow depends on viscosity and primary pressure.

***Volumetric dosing as absolute deviation in relation to one dispenser revolution. Depends on the viscosity of the material being dispensed.

Figure 1. eco-SPRAY Dimensions

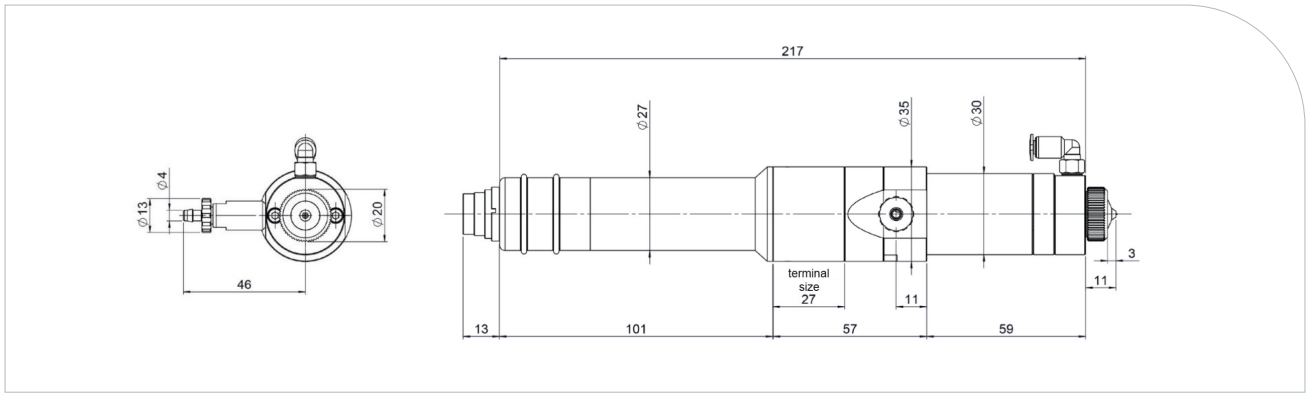

Figure 2. Comparison of Standard Spray Equipment and eco-SPRAY

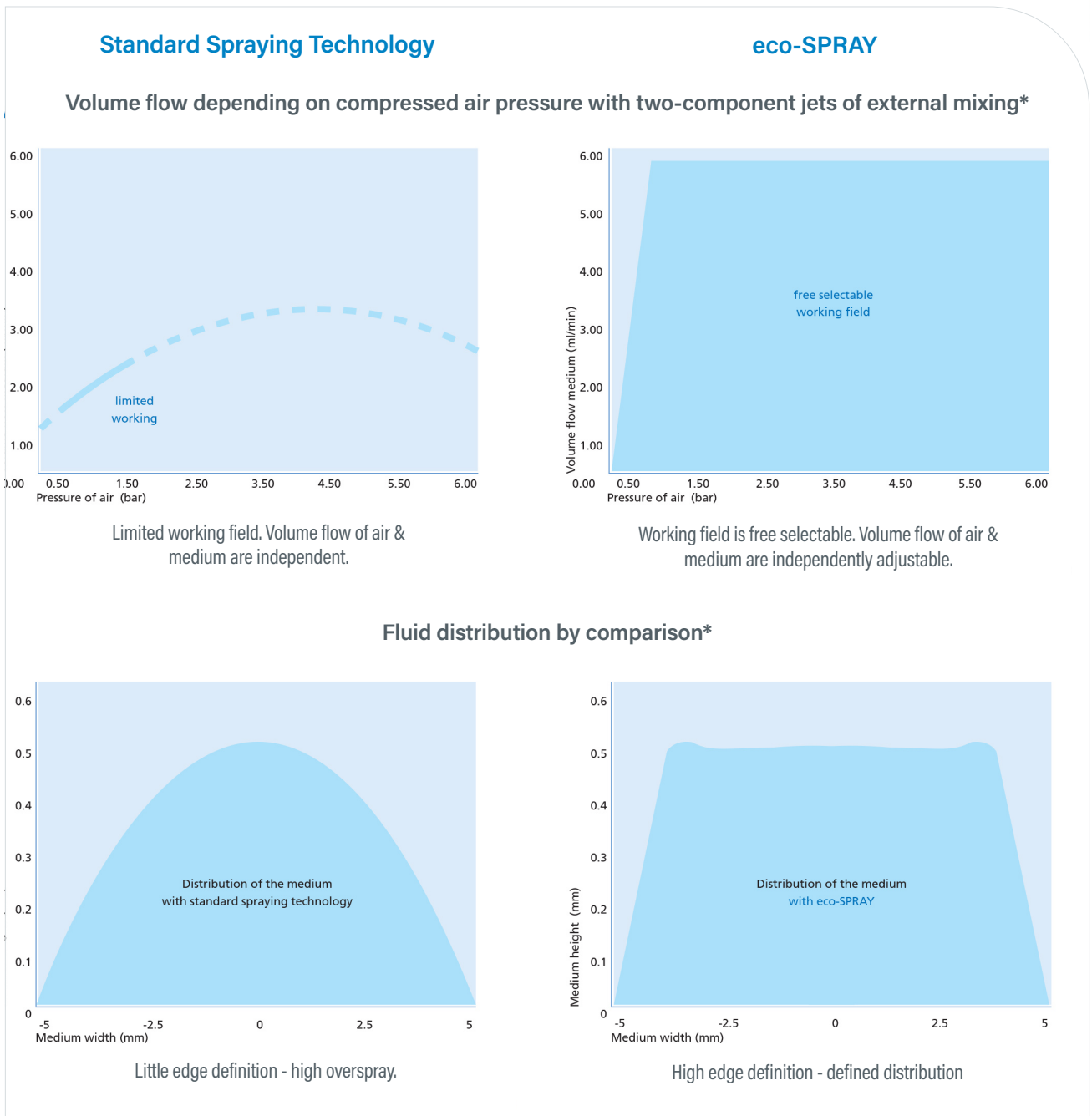
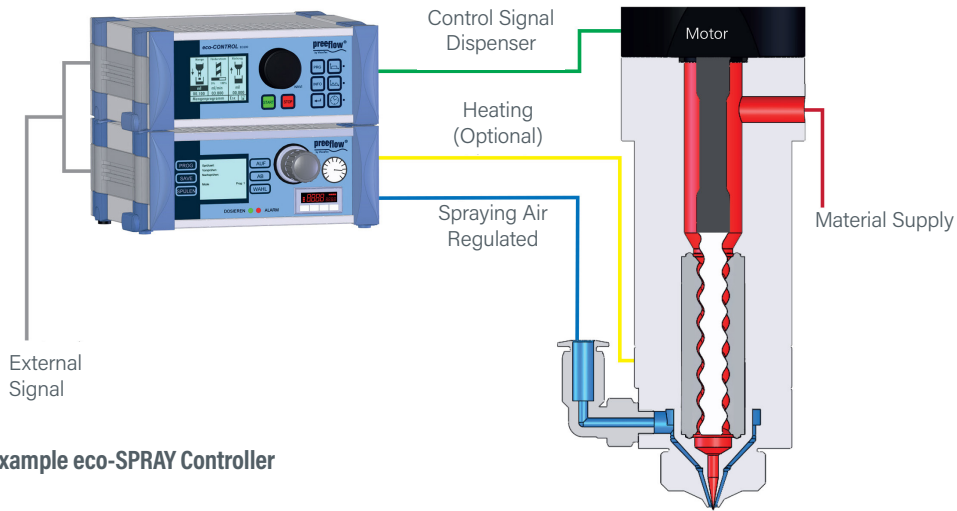
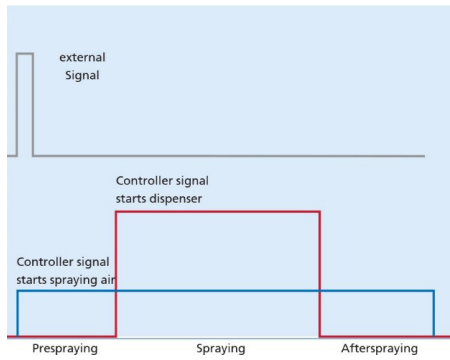

Figure 3. eco-SPRAY System



Switching Example eco-SPRAY Controller



Users can adjust pre-spraying, spraying, after-spraying, and pressure, making individual spray contours possible.



www.dymax.com

Americas
USA | +1.860.482.1010 | info@dymax.com

Europe
Germany | +49 611.962.7900 | info_de@dymax.com
Ireland | +353 21.237.3016 | info_ie@dymax.com

Asia
Singapore | +65.67522887 | info_ap@dymax.com
Shanghai | +86.21.37285759 | dymaxasia@dymax.com
Shenzhen | +86.755.83485759 | dymaxasia@dymax.com
Hong Kong | +852.2460.7038 | dymaxasia@dymax.com
Korea | +82.31.608.3434 | info_kr@dymax.com