



BlueWave[®] MX-275 LED Line-Pattern Flood-Curing Emitters

User Guide





About Dymax

Light-curable adhesives. Systems for light curing, fluid dispensing, and fluid packaging.

Dymax manufactures industrial adhesives, light-curable adhesives, epoxy resins, cyanoacrylates, and activator-cured adhesives. We also manufacture a complete line of manual fluid dispensing systems, automatic dispensing systems, and light-curing systems. Light-curing systems include LED light sources, spot, flood, and conveyor systems designed for compatibility and high performance with Dymax adhesives. Dymax adhesives and light-curing systems optimize the speed of automated assembly, allow for 100% in-line inspection, and increase throughput. System designs enable stand-alone configuration or integration into your existing assembly line.

Please note that most dispensing and curing system applications are unique. Dymax does not warrant the fitness of the product for the intended application. Any warranty applicable to the product, its application, and use is strictly limited to that contained in the Dymax standard Conditions of Sale. Dymax recommends that any intended application be evaluated and tested by the user to ensure that desired performance criteria are satisfied. Dymax is willing to assist users in their performance testing and evaluation. Data sheets are available for valve controllers or pressure pots upon request.

Contents

Introduction	4
Where to Get Help	4
Safety	4
Product Overview	5
Description of BlueWave MX-275 Emitters	5
Unpacking	5
Parts Included	6
Installation	6
Important Information.....	6
Mounting/Connections	6
Operation	8
Troubleshooting & Maintenance	9
Product Cleaning and Care.....	10
Glass Window Replacement.....	10
Spare Parts	11
Compatible Devices	12
Specifications	13
Declaration of Conformity	14
Warranty	15
Index	15

Introduction

This guide describes how to set up, use, and maintain BlueWave® MX-275 emitters safely and efficiently.

Intended Audience

This user guide is meant for experienced process engineers, technicians, and manufacturing personnel. If you are new to high-intensity LED light sources and do not understand the instructions, contact Dymax Application Engineering for answers to your questions before using the equipment.

Where to Get Help

Customer Support and Applications Engineering teams are available by phone and email in Germany, Monday through Friday, from 8:00 a.m. to 5:00 p.m. Central European Time. You can also email Dymax Europe GmbH at info_de@dymax.com. Please see the back cover for worldwide contact information. For more information about this product, visit dymax.com.

Safety



WARNING! *If you use this UV LED light source without first reading and understanding the information in the UV Light Safety Guide, SAF001, injury can result from exposure to high-intensity light. To reduce the risk of injury, please read and ensure you understand the information in that guide before assembling and operating the Dymax UV LED light source.*



Specific Safety statements for this device:

This device falls under IEC 62471 Risk Group 3 for UVA and Blue Light Emissions:

WARNING. *UV emitted from this product. Avoid eye and skin exposure to unshielded products.*

WARNING. *Possibly hazardous optical radiation emitted from this product. Do not look at operating lamp. Eye injury may result.*

Product Overview

Description of BlueWave MX-275 Emitters

- When paired with a MX-series controller, BlueWave MX-275 emitters function as line-pattern flood curing systems with 5 mm x 50 mm (0.2" x 2") active curing areas.
- The BlueWave MX-275 emitter is air cooled using an axial fan.
- The BlueWave MX-275 emitter can be mounted using one of two-hole patterns in the housing body.

Figure 1.
BlueWave MX-275 Emitter
(RediCure® Version Show)



Unpacking

Upon arrival, inspect all boxes for damage and notify the shipper of box damage immediately. Open each box and check for equipment damage. If parts are damaged, notify the shipper and submit a claim for the damaged parts. Contact Dymax so that new parts can be shipped to you immediately.



WARNING! *Until the BlueWave MX-275 emitter is attached to a controller via the interconnect cable it is susceptible to ESD damage, handle according to ESD standards using a ground strap and do not touch exposed connector pins.*

The parts below are included in every package/order. If parts are missing from your order, contact your local Dymax representative or Dymax Customer Support to resolve the problem.

Parts Included

- LED Emitter Assembly
- User Guide

Installation

The BlueWave MX-275 emitter is part of a BlueWave® MX-series curing system and requires connection to a controller via an interconnect cable for proper operation.

Important Information

- Do not connect any components while power is applied.
- Mount the BlueWave MX-275 emitter to a rigid support, such as the emitter stand PN 42390, prior to connecting the interconnect cable to prevent handling damage.
- Do not touch the emitter aperture glass. This can result in poor performance and broken glass due to heating. Inspect before each use and clean with isopropyl alcohol if contaminated.
- If emitter aperture glass is permanently contaminated it must be replaced for safe operation.

Mounting/Connections

- Each emitter has two sets of M3 x 0.5 mm holes (Figure 2) that align with Dymax stands and holders.
- When connecting the emitter to the controller, ensure proper strain relief to prevent pinching or kinking of the interconnect cable.
- The cooling air intake on top of unit must be free flowing, do not cover.
- Exhausting air on the sides must be given at least 1 mm (0.04") of clear space to obstructions for safe use.

Figure 2.
BlueWave MX-275 Emitter Dimensions

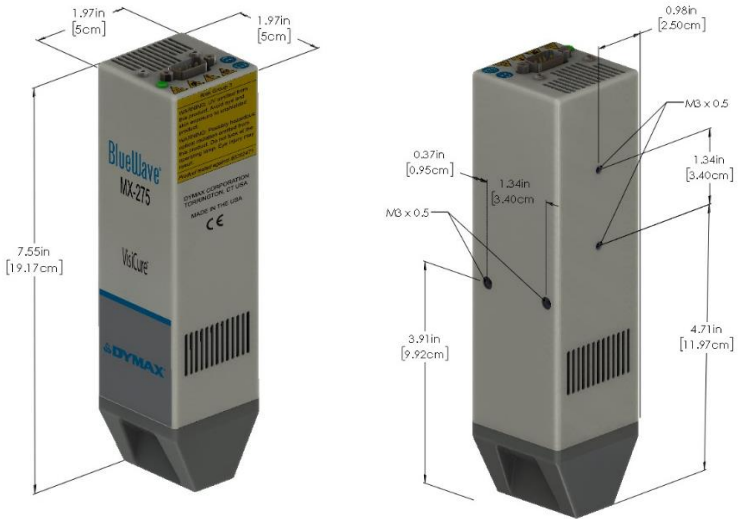

- When mounting multiple emitters side-by-side (**Figure 3**) maintain 1 mm (0.04") of clear space between units. The outermost units must have 20 mm (0.8") clear space from obstructions for safe use.

Figure 3.
Example of Installation Using Array Stand

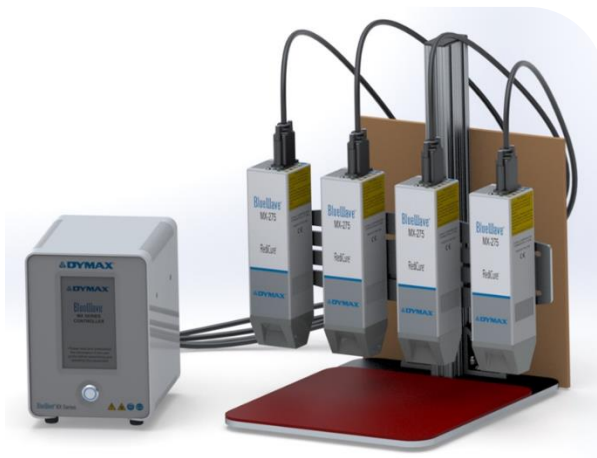

Operation

- The BlueWave MX-275 emitter, when attached to the appropriate controller, will create a fan noise during startup and during high output operation. This is normal and is not of concern unless there is a temperature warning on the controller.
- Always verify proper light shielding is in place prior to starting to process using the emitter.
- The green status LED on the top of the unit may be observed directly to indicate the emitter is commanded to be on.



WARNING! *Looking directly at the high-intensity light emitted by the BlueWave MX-series emitters can result in eye injury. To prevent eye injury, never look directly at the energy-emitting end of the high-intensity emitter and always wear protective goggles. To avoid accidental exposure, always point the emitter at the curing substrate.*

Troubleshooting & Maintenance

Problem	Possible Cause	Corrective Action
BlueWave MX-275 LED does not produce light	LED intensity adjustment set to 0% or too low	Increase LED intensity setting.
	LED cycle time is set to 0 seconds	0 Seconds sets manual mode and requires a trigger.
	Interlock is open	Verify interlock jumpers are in place. Verify PLC command structure for PLC mode.
	Interface cable connections loose or damaged	Check connections and condition of interface cable.
	Trigger setting not matched to input.	Trigger setting on admin screen should match the desired input trigger channel.
	LED head is not connected to the correct port/channel	Verify that the head is connected to the desired port/channel.
BlueWave MX-275 LED suddenly stops producing light	Over-temperature shutdown was triggered	Verify alarms.
	Footswitch defective	Activate unit using the front control panel. Replace the footswitch if the unit operates from the front control panel.
	Interlock is open.	Verify interlock jumpers are in place. Verify PLC command structure for PLC mode.
BlueWave MX-275 LED provides only low-intensity light	LED intensity adjustment set to minimum	Increase LED intensity setting on admin settings or I/O input for PLC mode.
	Contaminated/dirty lens optics	Clean the surface of the lens.

Product Cleaning and Care

- Product cleaning is limited to wiping the product with a damp cloth. Do not soak. Isopropanol Alcohol or household cleaners may be used for cleaning the product.
- Always inspect the quartz window for cleanliness before use. Foreign material can cause permanent damage to the window. Clean with Isopropanol Alcohol to remove smudges or foreign material. Damaged or permanently etched windows should be replaced.
- Do not use compressed air to removed particle debris inside the emitter as it may damage the high-speed cooling fan.

Glass Window Replacement

(Kit 43362)

1. Before starting, disconnect power to the unit.
2. Lay the emitter on its side with the cover facing forward. Using a Philips #1 screwdriver, loosen and fully remove the two screws (Figure 4).
3. Remove the glass retaining plate being careful not to lose the O-rings.

Figure 4.
Remove Screws

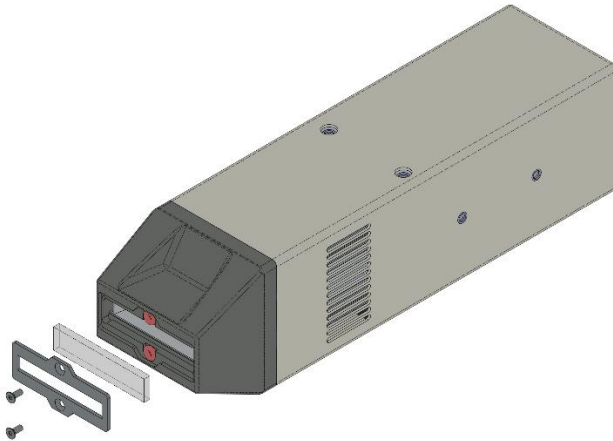

NOTE: If the old window has shattered, be sure to remove all debris before attempting to install the new glass window.

4. Wearing vinyl or cotton gloves unwrap the new window and carefully clean with the enclosed alcohol swab. Holding the window by its sides lay it into the cavity of the emitter. Take care not to touch the glass with bare hands, as any residue left on the window can adversely affect the performance of the unit.
5. Clean the glass retaining plate removed in Step 3.
6. Locate and place the O-rings into the emitter nose pockets prior to installing the glass retaining plate.
7. Assemble the two screws removed in Step 2 and lightly tighten.

Spare Parts

Item	Part Number
BlueWave MX-275 Emitter Glass Replacement Kit	43362

Compatible Devices

Item	Part Number
Controllers	
BlueWave® MX Series 2-Channel Controller/Power Supply	43184*
BlueWave® MX Series 4-Channel Controller/Power Supply	43181*
Emitters	
BlueWave MX-275, RediCure® (365 nm)	43094
BlueWave MX-275, PrimeCure® (385 nm)	43098
BlueWave MX-275, VisiCure® (405 nm)	43102
System Components	
Interconnect Cable Assembly - 2 Meter	42287
Interconnect Cable Assembly - 5 Meter	42889
Extended Interconnect Cable - 10 Meter**	43010
Extended Interconnect Cable - 20 Meter**	43011
Radiometer	
ACCU-CAL™ 50-LED Radiometer	40505
Stands	
Array Stand	43070
Single Emitter Mounting Stand	42390
Dual Emitter Mounting Bracket for MX Controller	60868
Personal Protection Equipment	
Three-Sided Acrylic Shield	41395
Protective Goggles — Green	35286
Protective Goggles — Gray (standard model included with unit)	35285
Face Shield	35186

* Appropriate power cord included for European customers

** Intended for machine installations only

Specifications



Property	Specification		
Emitter	RediCure	PrimeCure	VisiCure
Output Frequency	365 nm	385 nm	405 nm
Intensity Output*			
10-mm Work Distance	1,460 mW/cm ²	1,870 mW/cm ²	1,750 mW/cm ²
25-mm Work Distance	960 mW/cm ²	1,220 mW/cm ²	1,100 mW/cm ²
Emitter Dimensions (W x D x H)	1.97" x 1.97" x 7.55" [5 cm x 5 cm x 19.2 cm]		
Weight	Emitter: 1.64 lbs. (0.74 kg)		
Unit Warranty	1 year from purchase date		
Operating Environment	10°C to 40°C (50°F to 104°F)		

* Measured using a Dymax ACCU-CAL™ 50-LED Radiometer with 3-mm aperture prototype. This is preliminary intensity data for reference, tests using flood mode without an aperture will yield different results.

Figure 5.
BlueWave MX Series Spectral Output

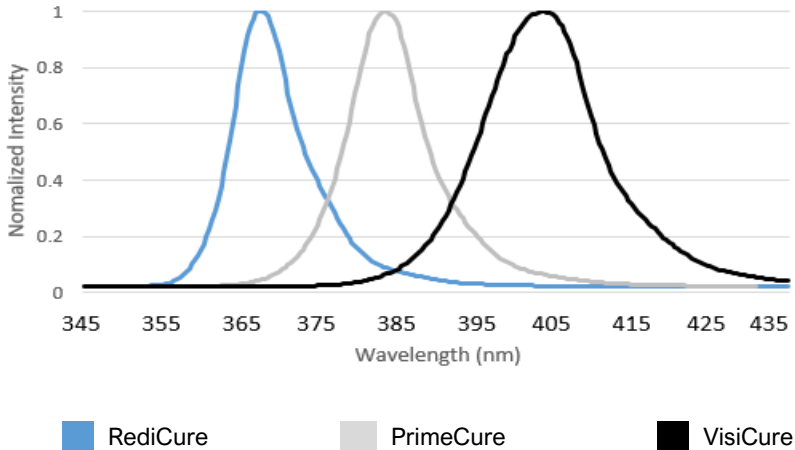

Declaration of Conformity



Declaration of Conformity

Manufacturer:
Dymax Corporation
318 Industrial Lane
Torrington, CT 06790, USA

European Address:
Dymax Europe GmbH
Kasteler Str.45
Geb.G359
Wiesbaden Germany 65203

UK Address:
Dymax
1b Hunts Grove Drive, Hardwick,
Gloucester, Gloucestershire, GL2 4BH
United Kingdom

Product description: BlueWave® MX-275 LED Line Curing System
Model name(s): BlueWave® MX 275 LED Emitter

This product complies with the following Directives, legal acts and standards:

European Union Compliance (CE)

Electromagnetic Compatibility Directive (2014/30/EU):
EN 55011:2009 + A1:2010
EN 61000-3-2:2014 Class A
EN 61000-3-3:2013
EN 61326-1:2013

Other Regulatory Compliance

Photo-biological Safety
IEC 62471 (2006)

Low Voltage Directive (2014/35/EU):
EN 61010-1:2010 (3rd Edition)

RoHS Directive EU (2015/863)



Declaration:

I declare that the above information in relation to the supply and manufacture of this product is in conformity with the above standards and directives.

3-10-2021

Name

Date

Authorized Signatory:

Richard MacCutcheon
Engineering Manager
Dymax Corporation
Torrington, CT., USA

Representative in Europe:

Dominik Stephan
Director, Equipment
Dymax Europe GmbH
Wiesbaden, Germany

Representative in UK:

Kevin Westcott
Account Manager
Dymax
Gloucester, United Kingdom

www.dymax.com

Americas
USA | +1.888.682.1010 | info@dymax.com

Europe
Germany | +49 611 982 7980 | info_eu@dymax.com
Ireland | +353 21 237 3910 | info_ie@dymax.com

Asia
Singapore | +65 67522887 | info_ap@dymax.com
Shanghai | +86 21 37265755 | dymaxasia@dymax.com
Shenzhen | +86 755 83487759 | dymaxasia@dymax.com
Hong Kong | +852 2460 7138 | dymaxasia@dymax.com
Korea | +82 31 688 3434 | info_ko@dymax.com

©2020 Dymax Corporation. All rights reserved. All trademarks in this guide, except where noted, are the property of, or used under license by, Dymax Corporation, U.S.A.

Warranty

From date of purchase, Dymax Corporation offers a one-year warranty against defects in material and workmanship on all system components with proof of purchase and purchase date. Unauthorized repair, modification, or improper use of equipment may void your warranty benefits. The use of aftermarket replacement parts not supplied or approved by Dymax Corporation, will void any effective warranties and may result in damage to the equipment.

IMPORTANT NOTE: DYMAX CORPORATION RESERVES THE RIGHT TO INVALIDATE ANY WARRANTIES, EXPRESSED OR IMPLIED, DUE TO ANY REPAIRS PERFORMED OR ATTEMPTED ON DYMAX EQUIPMENT WITHOUT WRITTEN AUTHORIZATION FROM DYMAX. THOSE CORRECTIVE ACTIONS LISTED ABOVE ARE LIMITED TO THIS AUTHORIZATION.

Index

Cleaning, 10	Product Overview, 5
Compatible Devices, 12	Safety, 4
Components, 5	Spare Parts, 11
Declaration of Conformity, 14	Specifications, 13
Glass Window Replacement, 10	Spectral Output, 13
Help, 4	Support, 4
Installation, 6	Troubleshooting, 9
Maintenance, 9	Unpacking, 5
Operation, 8	Warranty, 15
Parts List, 6	



Americas

USA | +1.860.482.1010 | info@dymax.com

Europe

Germany | +49 611.962.7900 | info_de@dymax.com
Ireland | +353 21.237.3016 | info_ie@dymax.com

Asia

Singapore | +65.67522887 | info_ap@dymax.com
Shanghai | +86.21.37285759 | dymaxasia@dymax.com
Shenzhen | +86.755.83485759 | dymaxasia@dymax.com
Hong Kong | +852.2460.7038 | dymaxasia@dymax.com
Korea | +82.31.608.3434 | info_kr@dymax.com

© 2019-2020 Dymax Corporation. All rights reserved. All trademarks in this guide, except where noted, are the property of, or used under license by Dymax Corporation, U.S.A.

The data contained in this bulletin is of a general nature and is based on laboratory test conditions. Dymax Europe GmbH does not warrant the data contained in this bulletin. Any warranty applicable to products, its application and use is strictly limited to that contained in Dymax Europe GmbH's General Terms and Conditions of Sale published on our website. Dymax Europe GmbH does not assume any responsibility for test or performance results obtained by users. It is the user's responsibility to determine the suitability for the product application and purposes and the suitability for use in the user's intended manufacturing apparatus and methods. The user should adopt such precautions and use guidelines as may be reasonably advisable or necessary for the protection of property and persons. Nothing in this bulletin shall act as a representation that the product use or application will not infringe a patent owned by someone other than Dymax Corporation or act as a grant of license under any Dymax Corporation Patent. Dymax Europe GmbH recommends that each user adequately test its proposed use and application of the products before actual repetitive use, using the data contained in this bulletin as a general guide. MAN093EU 5/6/2021