

UV Light Shield

For use with ECE Flood Systems
User Guide

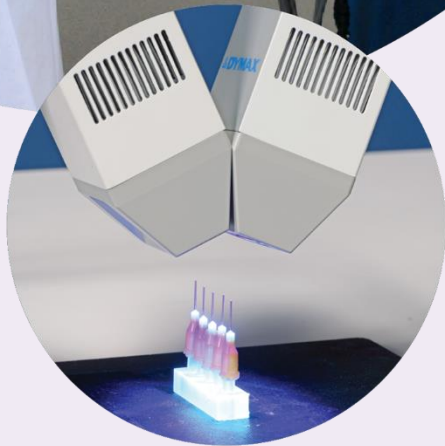



About Dymax

UV/Visible light-curable adhesives. Systems for light curing, fluid dispensing, and fluid packaging.

Dymax manufactures industrial, light-curable, epoxy, and activator-cured adhesives. We also manufacture a complete line of manual fluid dispensing systems, automatic fluid dispensing systems, and light-curing systems. Light-curing systems include LED light sources, spot, flood, and conveyor systems designed for compatibility and high performance with Dymax adhesives.

Dymax adhesives and light-curing systems optimize the speed of automated assembly, allow for 100% in-line inspection, and increase throughput. System designs enable stand-alone configuration or integration into your existing assembly line.

Please note that most dispensing and curing system applications are unique. Dymax does not warrant the fitness of the product for the intended application. Any warranty applicable to the product, its application, and use is strictly limited to that contained in the Dymax standard Conditions of Sale. Dymax recommends that any intended application be evaluated and tested by the user to ensure that desired performance criteria are satisfied. Dymax is willing to assist users in their performance testing and evaluation by offering equipment trial rental and leasing programs to assist in such testing and evaluations. Data sheets are available for valve controllers or pressure pots upon request.

Contents

Introduction	4
Where to Get Help.....	4
Safety	4
General Safety Considerations	4
Specific Safety Considerations.....	4
Safety Symbol Index	5
Product Overview	5
Description of the UV Light Shield	5
System Components.....	6
Special Features and Benefits	6
Assembly and Setup	7
Unpacking and Inspecting Your Shipment.....	7
Parts Included in the ECE Light Shield.....	7
System Interconnection.....	7
Operation.....	10
Cleaning and Maintenance	10
General	10
Spare Parts and Accessories	11
Specifications.....	11
Warranty	13
Index	13

Introduction

This guide describes how to assemble, use, and maintain the Dymax UV ECE Light Shield safely and efficiently.

Intended Audience

Dymax prepared this user guide for experienced process engineers, technicians, and manufacturing personnel. If you are new to UV light curing and do not understand the instructions, contact Dymax Application Engineering to answer your questions before using the equipment.

Where to Get Help

Dymax Customer Support and Application Engineering teams are available in the United States, Monday through Friday, from 8:00 a.m. to 5:30 p.m. Eastern Standard Time. You can also email Dymax at info@dymax.com. Contact information for additional Dymax locations can be found on the back cover of this user guide.

Additional resources are available to ensure a trouble-free experience with our products:

- Detailed product information on www.dymax.com
- Dymax adhesive Product Data Sheets (PDS) on our website
- Material Safety Data Sheets (SDS) provided with shipments of Dymax adhesives

Safety



WARNING! *If you use this UV light shield without first reading and understanding the information in this user guide, injury can result from exposure to high-intensity light. To reduce the risk of injury, read and ensure you understand the information in this user guide before assembling and operating a Dymax flood lamp system with light shield.*

General Safety Considerations

All users of Dymax equipment should read and understand this user guide before assembling and using the equipment.

To learn about the safe handling and use of light-curable formulations, obtain, and read the MSDS for each product. Dymax includes an SDS with each adhesive sold. In addition, fluid product SDS can be requested on the Dymax website.

Specific Safety Considerations

The light shield is designed to maximize operator safety and minimize exposure to light-curing energy. To use the shield safely, it must be set up and operated in accordance with the instructions in this user guide. Please also read and understand the safety considerations unique to flood lamp light-curing systems.

Safety Symbol Index

The following symbols are displayed on the Dymax light shield. Please see below for their meanings.



Refer to Manual



Gloves Required



Eye Protection Required



Warning!



Caution! Hot Surface



Warning! UV Light Hazard

Product Overview

Description of the UV Light Shield

The UV light shield is part of a flood lamp light-curing system that incorporates an optional shutter and a light source into a unique system, generating conditioned quality UV light for curing photosensitive adhesives, coatings, and inks applied to various size and shape parts. There is a choice of two types of shutters and two flood lamp models which can be integrated into the system to optimize your application and provide higher throughput at the best curing quality. The flood-lamp curing system can also be used without the shutter in rare cases when especially long (several hours) exposure is needed, or timing accuracy is not an issue.

The UV light shield can accommodate Dymax ECE flood lamps.

NOTE: Users considering special or customized configurations should contact Dymax Application Engineering for recommendations and/or guidance to prevent equipment malfunction. Dymax cannot foresee every possible use of these light sources and reserves the right to invalidate warranties, expressed or implied, due to non-recommended installation or use of this equipment.

System Components

The light shield is the base of the flood lamp system. It is constructed so the operator can safely observe objects in the curing process.

The light shield features a front-loading door which swings up and down on the dual supporting hinges. The door has an interlock switch that prevents the shutter from being open when the light shield door is open.

The included fireproof tray slides along the adjustable height rails and can be removed and replaced with ease.

Figure 1.
Main Components of the ECE Light Shield

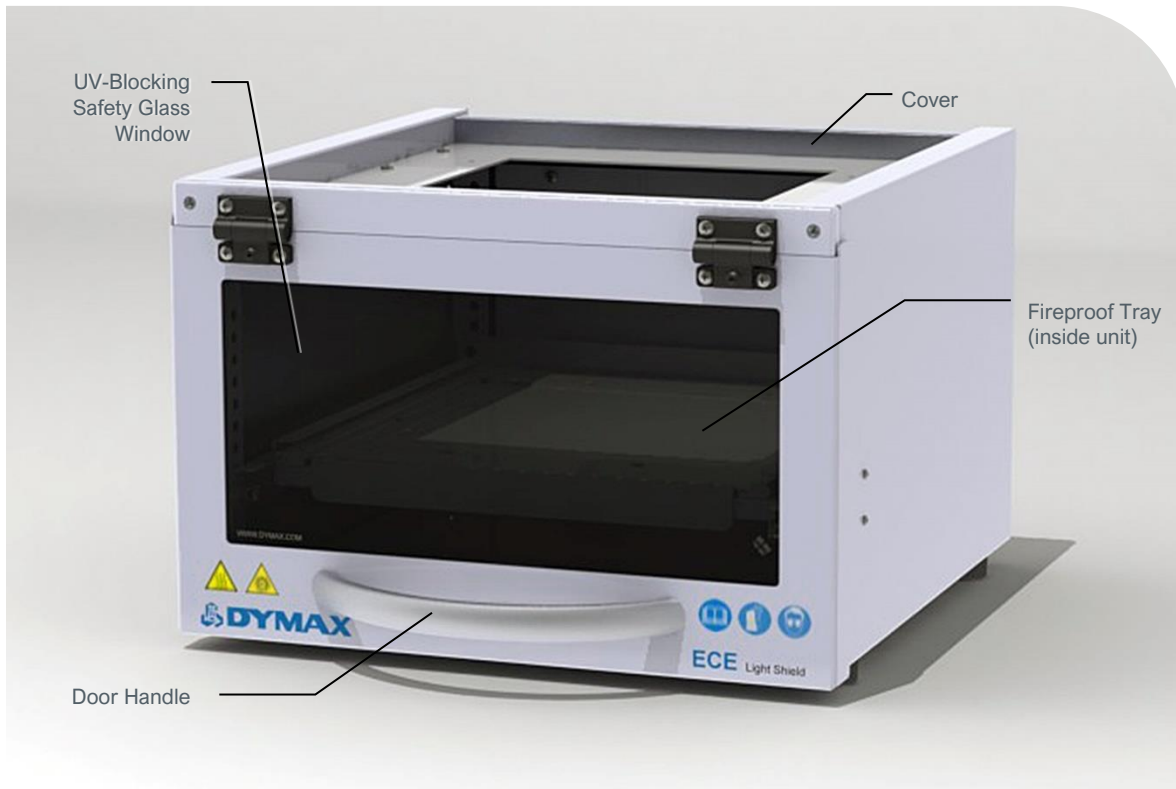

Special Features and Benefits

Key features include:

Feature	Benefit
Accommodates parts for curing up to 7.5" [19.05 cm] high	Can be used for a variety of part configurations.
Work surface may be adjusted from 1.5"- 5.5" [3.81 cm - 13.97 cm] from the cover of the enclosure.	The light shield tray can be used with light-curing applications for a variety of size products.
Door interlock	Extra safety precaution preventing the shutter from being open when the light shield door is open.

Assembly and Setup

Unpacking and Inspecting Your Shipment

When your UV Light Shield arrives, inspect the boxes for damage and notify the shipper of box damage immediately.

Open each box and check for equipment damage. If parts are damaged, notify the shipper and submit a claim for the damaged parts. Contact Dymax so that new parts can be shipped to you immediately.

Check that the parts included in your order match those listed below. If parts are missing, contact your local Dymax representative or Dymax Customer Support to resolve the problem.

Parts Included in the ECE Light Shield

- ECE Light Shield with Tray (1)
- Interface Cable (2)
- Adapter Plate (3)
- Dymax ECE Light Shield User Guide (4)

Figure 2.
ECE Light Shield (PN 40785) Components

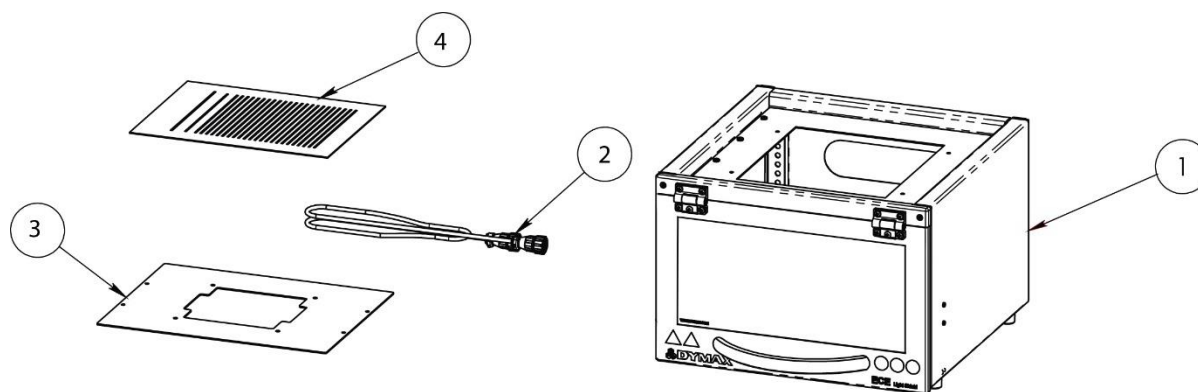

System Interconnection

Place the Light Shield on the designated workbench. Remove all packaging used for securing the unit during shipping and save it in the event you need to repackage the unit for return.

Suggested Sequence of Flood Lamp Curing System Connection

1. Install the Bulb (included) into the Reflector Housing Assembly; follow the installation instructions provided with the Bulb.
2. Connect the Connection Cable to the J2 port on the rear panel of the Power Supply and then to the 8-Pin Receptacle in the rear of the Reflector Housing Assembly.
3. Connect the Foot Pedal to 4-Pin Receptacle right rear of the Shutter.
4. Connect the Cable provided with the Shutter from the 8-Pin Connector on the rear of the Power Supply to the 8-Pin Connector on the rear of the ZIP™ Shutter.

5. Connect the Cable provided with the Light Shield from the 9-Pin Connector on the rear of Power Supply to the 9-Pin Connector located on back of Light Shield.
6. Plug the female connector of an AC Power Cord into the male receptacle on the rear panel of the Power Supply.

Figure 3.
Suggested Flood-Lamp Curing System Interconnect

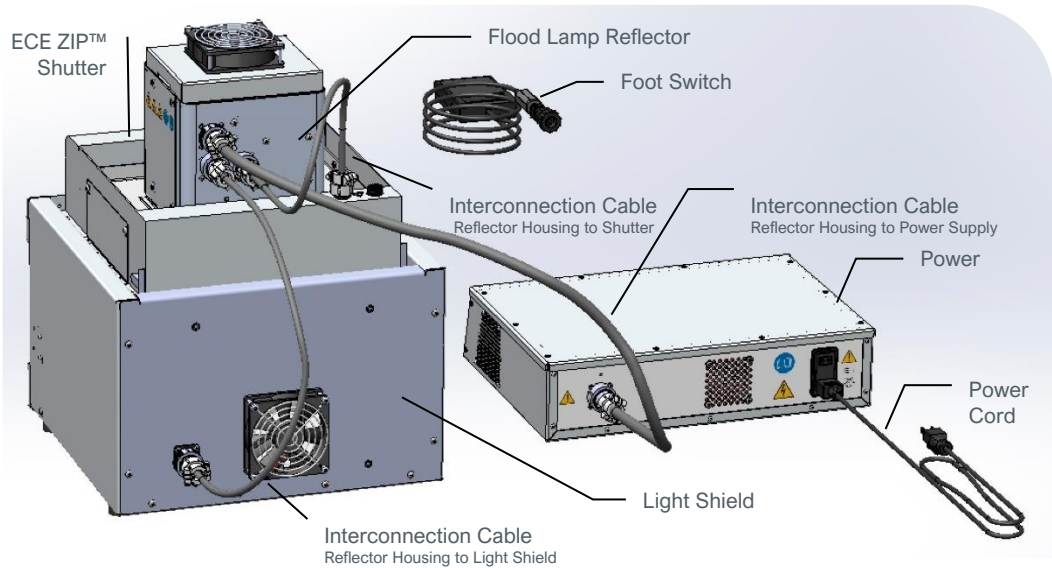

WARNING! Do not position the Light Shield on top of the Power Supply (Figure 4). The ECE Flood Lamp System requires adequate air circulation. Setting up the system in such a configuration can result in damage to the equipment and unsafe operating conditions.

Figure 4.
Unacceptable Mounting Configuration



Installing the Light Shield with a Reflector Housing and ECE ZIP™ Shutter

1. Take the ECE ZIP™ Shutter and carefully place it on the top of the Light Shield.
2. Install the Securing Brackets to the top of Light Shield with the M4 x 8 mm screws provided.

NOTE: Do not tighten until directed to in Step 5.

3. Prepare the Reflector Housing with the appropriate Mounting Plate(s) for use with the Shutters as described in the Shutter manuals (Figure 5).

NOTE: Do not install the Reflector Housing to the Shutter by installing the four M4 x 8 mm screws and fastening the Support Plate to the Reflector Housing until directed.

Figure 5.
Reflector Housing with Mounting Plate

ECE 5000

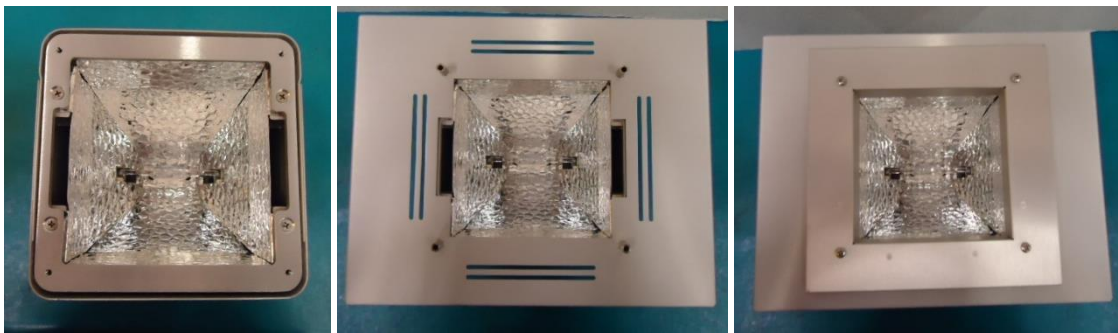

Reflector Housing

Reflector Housing with Mounting Plate

Reflector Housing with Mounting Plate
Air Plenum

ECE 2000



Reflector Housing

Reflector Housing with Mounting Plate

4. Place the Reflector Housing/Support Plate(s) Assembly into the Shutter. Using the M4 x 8 mm screws (Figure 6) provided with the Shutter, secure the Light Shield and Shutter to the Reflector Housing Support Plate(s) Assembly.
5. Center the Shutter on the Light Shield. When the desired position is achieved, tighten the Securing Brackets to the Light Shield.

Figure 6.
Securing Bracket for Light Shield

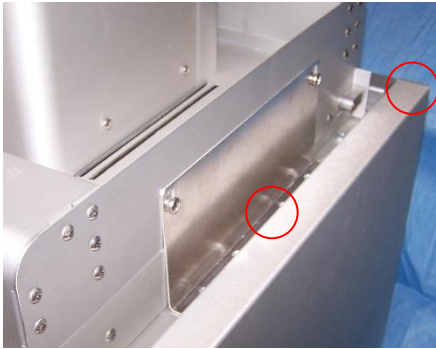

Figure 7.
Installed System (ECE 5000)



Operation

For a detailed description of flood lamp operation, maintenance, and troubleshooting, see the appropriate flood lamp operation manual. This is a suggested sequence of activities that can be altered to better match your working conditions, process requirements, and work habits.

Estimate the height of the curing part in respect to its base, or to the base of the part holder (if the object to be cured is not free standing), and then adjust the position of the work surface to a proper distance from the curing part. Use a ruler for setting accuracy.

The recommended working distances for each type of reflector housing assembly is indicated in the appropriate flood lamp manual. You can set this distance differently to optimize your throughput with respect to adhesive properties and irradiant energy required to achieve the best curing quality in the shortest time. Dymax Application Engineering is ready to assist you if needed.

Cleaning and Maintenance

General

For detailed technical assistance, please call the Dymax Application Engineering.

UV Light Shield

The UV light shield is designed to be maintenance free. Periodic cleaning will ensure long trouble-free operation.

Flood Lamps

See the appropriate flood lamp manual for maintenance recommendations.

Shutters

See the appropriate shutter manual for maintenance recommendations.

Spare Parts and Accessories

Item	Part Number
Cables	
Reflector Housing to Light Shield Cable	40878
Interlock Switches	
Snap Switch, DPDT 15A Lever QC	40921
Snap Switch, Mini	40866
Misc. Replacement Parts	
Front Door Handle	40808
Hinge, Friction, Adjustable	36447
Fan Assembly, 24 Volts	40823
Work Surface Tray Assembly	40806
Shields	
Door Assembly Shield	40851
Housing Light Shield	40793
Plate Top Shield	40802

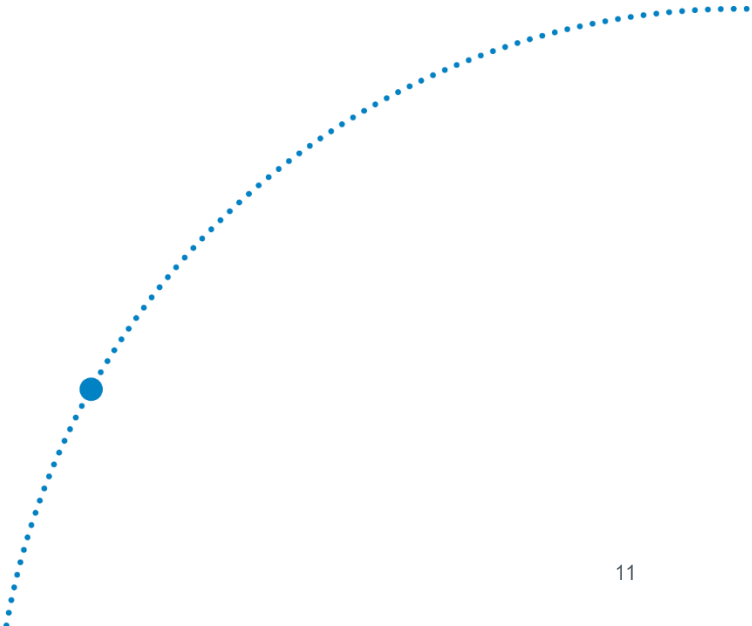

Specifications



Property	Specification
Part Number	40785
Compatible Dymax Flood Lamps	ECE 5000 & ECE 2000
Compatible Dymax Bulbs	Standard – 400 Watt Metal Halide Bulb Optional – 400 Watt Hg Vapor Bulb Optional – 400 Watt Visible Bulb
Work Area	10" x 10" [25.4 cm x 25.4 cm]
Work Surface Load Capacity	Up to 5 lbs. [2.27 kg]
Overall Dimensions (W x D x H)	15.1" x 18.2" x 10.6" [38.42 cm x 46.25 cm x 26.83 cm]
Interface Cable Length (standard)	24" [60.96 cm]
Weight (Light Shield Only)	12.75 lbs [5.78 kg]
Unit Warranty	1 year from purchase date

Figure 8.
ECE Light Shield Dimensions

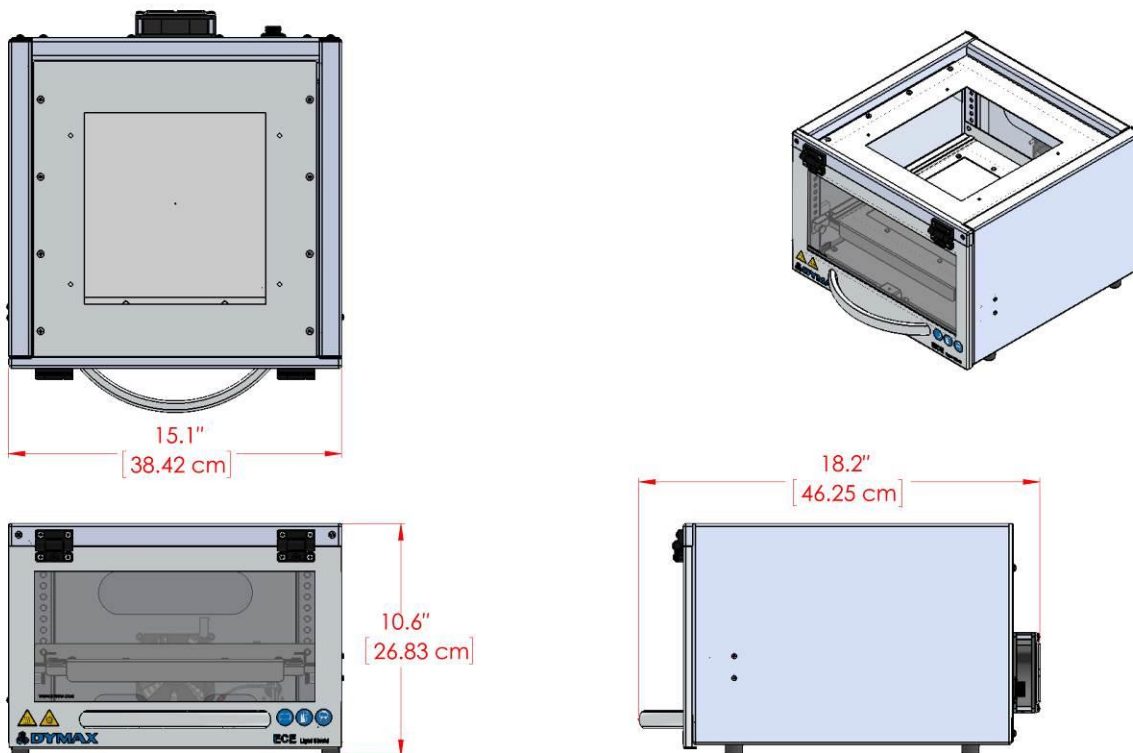

Warranty

From date of purchase, Dymax Corporation offers a one-year warranty against defects in material and workmanship on all system components with proof of purchase and purchase date. Unauthorized repair, modification, or improper use of equipment may void your warranty benefits. The use of aftermarket replacement parts not supplied or approved by Dymax Corporation will void any effective warranties and may result in damage to the equipment.

IMPORTANT NOTE: *DYMAX CORPORATION RESERVES THE RIGHT TO INVALIDATE ANY WARRANTIES, EXPRESSED OR IMPLIED, DUE TO ANY REPAIRS PERFORMED OR ATTEMPTED ON DYMAX EQUIPMENT WITHOUT WRITTEN AUTHORIZATION FROM DYMAX. THOSE CORRECTIVE ACTIONS LISTED ABOVE ARE LIMITED TO THIS AUTHORIZATION.*

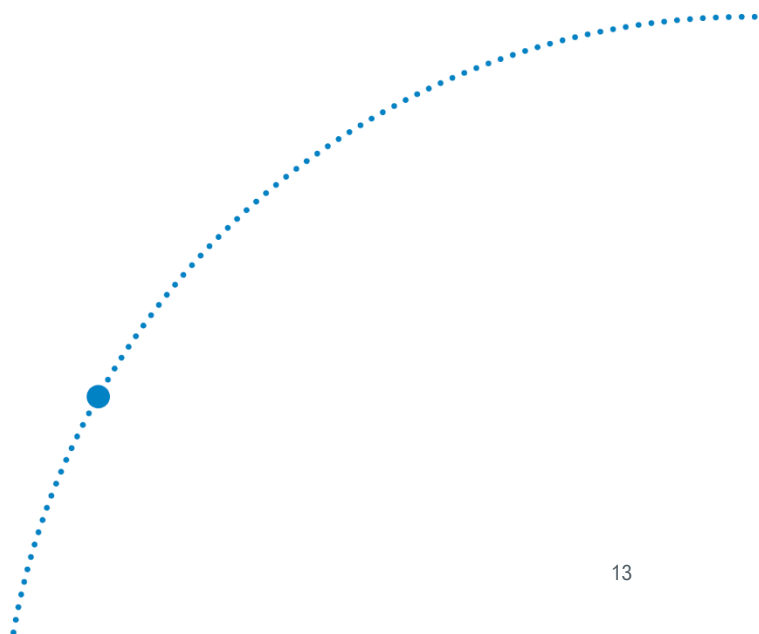

Index

- Assembly and Setup, 7
- Cleaning, 10
- Contact Information, 4
- Dimensions, 12
- Features and Benefits, 6
- Help, 4
- Maintenance, 10
- Operation, 10
- Optional Equipment, 11
- Parts Included, 7
- Product Overview, 5
- Safety, 4
 - General Safety Considerations, 4
 - Safety Symbol Index, 5
 - Specific Safety Considerations, 4
- Spare Parts and Accessories, 11
- Specifications, 12
- Support, 4
- System Components, 5
- System Interconnect, 7
 - Light Shield with Reflector Housing and Shutter, 8
- Unpacking, 7
- Warranty, 13



www.dymax.com

Americas

USA | +1.860.482.1010 | info@dymax.com

Europe

Germany | +49 611.962.7900 | info_de@dymax.com

Ireland | +353 21.237.3016 | info_ie@dymax.com

Asia

Singapore | +65.67522887 | info_ap@dymax.com

Shanghai | +86.21.37285759 | dymaxasia@dymax.com

Shenzhen | +86.755.83485759 | dymaxasia@dymax.com

Hong Kong | +852.2460.7038 | dymaxasia@dymax.com

Korea | +82.31.608.3434 | info_kr@dymax.com

© 2013-2021 Dymax Corporation. All rights reserved. All trademarks in this guide, except where noted, are the property of, or used under license by Dymax Corporation, U.S.A.

Please note that most dispensing and curing system applications are unique. Dymax does not warrant the fitness of the product for the intended application. Any warranty applicable to the product, its application and use is strictly limited to that contained in Dymax's standard Conditions of Sale. Dymax recommends that any intended application be evaluated and tested by the user to insure that desired performance criteria are satisfied. Dymax is willing to assist users in their performance testing and evaluation by offering equipment trial rental and leasing programs to assist in such testing and evaluations. Data sheets are available for valve controllers or pressure pots upon request.
PN 40981 MAN045 8/14/2013