

Model 826 Disposable Fluid Path Dispensing Valve

User Guide

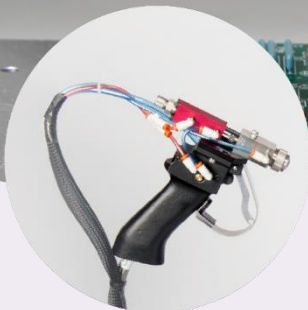
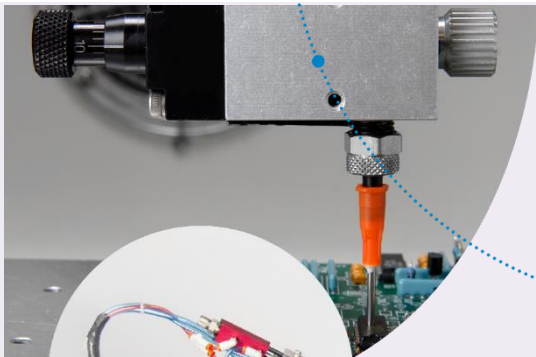

About Dymax

Light-curable adhesives. Systems for light curing, fluid dispensing, and fluid packaging.

Dymax manufactures industrial adhesives, light-curable adhesives, epoxy resins, cyanoacrylates, and activator-cured adhesives. We also manufacture a complete line of manual fluid dispensing systems, automatic dispensing systems, and light-curing systems. Light-curing systems include LED light sources, spot, flood, and conveyor systems designed for compatibility and high performance with Dymax adhesives. Dymax adhesives and light-curing systems optimize the speed of automated assembly, allow for 100% in-line inspection, and increase throughput. System designs enable stand-alone configuration or integration into your existing assembly line.

Please note that most dispensing and curing system applications are unique. Dymax does not warrant the fitness of the product for the intended application. Any warranty applicable to the product, its application, and use is strictly limited to that contained in the Dymax standard Conditions of Sale. Dymax recommends that any intended application be evaluated and tested by the user to ensure that desired performance criteria are satisfied. Dymax is willing to assist users in their performance testing and evaluation. Data sheets are available for valve controllers or pressure pots upon request.

Contents

Introduction	4
Where to Get Help.....	4
Safety	4
General Safety Considerations	5
Specific Safety Considerations.....	5
Product Overview	5
Description of the Model 826 Dispensing Valve.....	5
Special Features and Benefits of the Model 826	6
Disposable Fluid Path	7
Over-Pinch Adjustment.....	7
Suck-Back Feature.....	7
Assembly and Setup	7
Unpacking and Inspecting Your Shipment.....	7
Parts Included in the Model 826 Dispensing Valve.....	8
Tubing Installation	9
Mounting.....	9
System Interconnect.....	10
Material Flow & Suck-Back Adjustment	10
Operating the Dispensing Valve	13
Start Up.....	13
Dispense	13
Shut Off.....	14
Troubleshooting	15
Spare Parts and Accessories	16
Specifications	18
Warranty	19

Introduction

This guide describes how to assemble, use, and maintain the Dymax Model 826 dispensing valve safely and efficiently.

Intended Audience

Dymax prepared this user guide for experienced process engineers, maintenance technicians, and manufacturing personnel. If you are new to pneumatically operated fluid dispensing equipment and do not understand the instructions, contact Dymax Application Engineering to answer your questions before using the equipment.

Where to Get Help

Dymax Customer Support and Application Engineering teams are available in the United States, Monday through Friday, from 8:00 a.m. to 5:30 p.m. Eastern Standard Time. You can also email Dymax at info@dymax.com. Contact information for additional Dymax locations can be found on the back cover of this user guide.

Additional resources are available to ensure a trouble-free experience with our products:

- Detailed product information on www.dymax.com
- Dymax adhesive Product Data Sheets (PDS) on our website
- Safety Data Sheets (SDS) provided with shipments of Dymax adhesives

Safety



WARNING! *If you use this fluid dispensing equipment without first reading and understanding the information in this guide, personal injury can result from the uncontrolled release of high-pressure gas, injection injury, or exposure to chemicals. To reduce the risk of injury, read and understand this guide before assembling and using Dymax fluid dispensing equipment.*

General Safety Considerations

All users of Dymax fluid dispensing equipment should read and understand the user guide before assembling and using the equipment.

To learn about the safe handling and use of dispensing fluids, obtain and read the SDS for each fluid before using it. Dymax includes an SDS with each adhesive sold. SDS for Dymax products can be requested through the Dymax website.

Specific Safety Considerations

Using Safe Operating Pressures

Pressurizing the components in the dispensing system beyond the maximum recommended pressure can result in the rupturing of components and serious personal injury. To minimize the risk of rupturing components and injury, do not exceed the maximum operating pressure of the components in your fluid dispensing system (see system specifications on page 16).

Preventing Injection Injury

Discharging fluids or compressed air with a dispensing tip against your skin can cause very serious injection injury. To minimize the risk of injection injury, do not place the dispensing tip in contact with your skin.

Product Overview

Description of the Model 826 Dispensing Valve

The Model 826 is a dual-piston, normally closed pinch valve. This pneumatically operated valve dispenses a wide variety of materials but is specifically designed to easily dispense thicker, stringy materials. The 826 dispensing valve is highly precise, obtaining its precision from lockable controls that facilitate the adjustment of three critical parameters: the flow rate through the valve, the amount of tube closure, and suck-back.

Figure 1.
Model 826 Internal Component Diagram

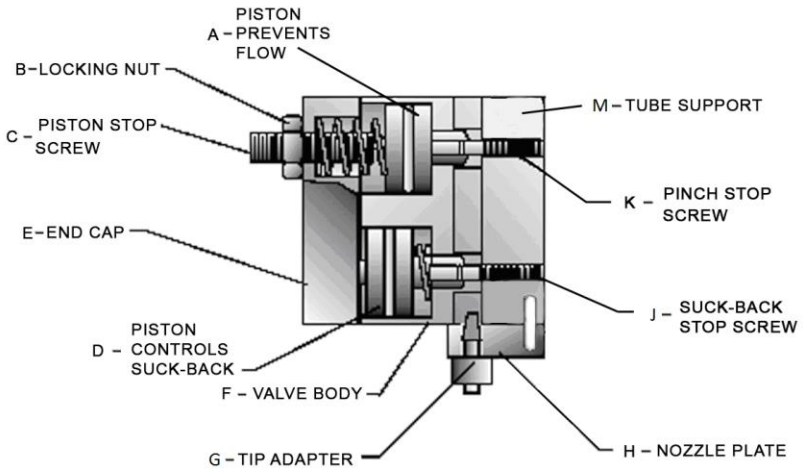

Special Features and Benefits of the Model 826

Feature	Benefit
Over-Pinch Adjustment	Prevents tubing damage, allowing users to secure millions of cycles from tubing before replacement is required
Disposable fluid path	Eliminates material contamination during dispense
	Prevent air entrapment during dispensing process
	Allows for easy product changeover with minimal cleanup
	Fluid and valve's inner components never come in contact, reducing valve maintenance and extending valve life
Adjustable Suck-back	Clean shutoff of thick, tacky, and/or stringy materials
	Minimizes skinning over of dispense tip

Disposable Fluid Path

The Model 826 valve features a disposable fluid path constructed out of tubing. Fluids are carried from the material reservoir to the dispense tip in a completely sealed path, ensuring no contact with the valve's inner parts. This reduces wear to the valve's inner parts, which reduces valve maintenance and extends the valve's life. It also ensures that fluids remain contaminate free throughout the dispensing process.

The Model 826 is compatible with a variety of different tubing sizes and materials ensuring complete compatibility with the fluids being dispensed. The disposable fluid path is easy to replace and change out, allowing for easy material changeover with little or no clean-up.

Over-Pinch Adjustment

All Dymax disposable fluid path valves contain a unique over-pinch adjustment feature. This adjustment can prevent damage to the fluid path, thereby extending the life of the tubing and reducing the amount it needs to be replaced.

Suck-Back Feature

The suck-back feature on the 826 valve allows for the clean shutoff of stringy and tacky materials and prevents the formation of a droplet at the end of the dispense nozzle. The suck-back feature also minimizes the "skinning" over of materials that tend to dry out at the end of the nozzle.

Assembly and Setup

Unpacking and Inspecting Your Shipment

When your Model 826 dispensing valve arrives, inspect the boxes and notify the shipper of any damage immediately.

Open each box and check for equipment damage. If parts are damaged, notify the shipper and submit a claim for the damaged parts. Contact Dymax so that new parts can be shipped to you immediately.

Check that the parts included in your order match those listed below. If parts are missing, contact your local Dymax representative or Dymax Customer Support to resolve the problem.

Figure 2.
Model 826 Pinch Valve



Parts Included in the Model 826 Dispensing Valve

- Model 826 pinch valve
- 0.25" [0.63 cm] OD black, polyethylene tubing
Note: Teflon®, silicone, and other tubing materials, along with a variety of fittings, are also available from Dymax.
- Assorted dispense tip kit
- Model 826 user guide

Tubing Installation

Figure 3.
Tubing Installation Procedure

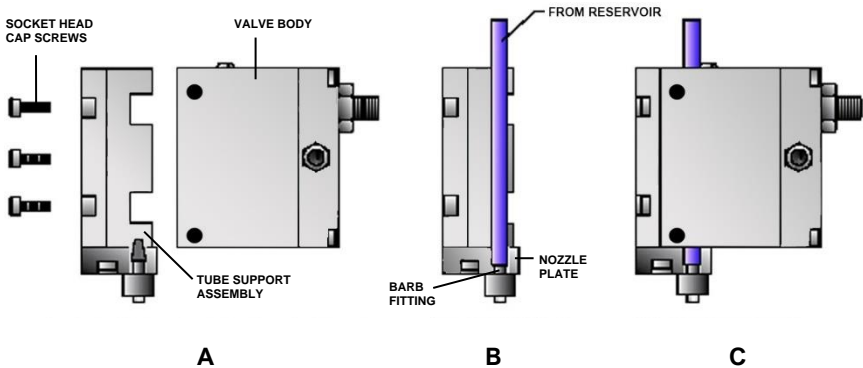

NOTE: The Model 826 is supplied with 0.25" (0.63 mm) O.D. polyethylene tubing. Other tubing sizes and materials (including polyurethane, PVC, and silicone) are available for order through Dymax. This valve is compatible with a maximum tubing size of 0.25" (0.63 cm) OD.

1. Remove the Tube Support Assembly by loosening the three 8-32 x 3/8" Socket Head Cap Screws (Figure 3, A).
2. Install the Tubing over the Barb Fitting on the Nozzle Plate or insert the Tubing through the hole provided (Figure 3, B).
3. Reinstall the Tubing Support Assembly to the Valve Body (Figure 3, C).

Mounting

NOTE: If the dispense valve is to be mounted in an area that limits access to the valve, it is recommended that the set-up operation be done prior to mounting. Access to various surfaces of the valve is necessary for periodic adjustment (see Specifications).

There are two 6-32 x .25 DP tapped holes on both sides of the dispense valve for mounting purposes (see Figure 9).

System Interconnect

Once the dispense valve is secured to its mounting surface, connect the air line to the port provided on the valve (Figure 4). Connect your air supply (60-90 psi [4.1- 6.3 bar]) to your valve controller or 3-way solenoid valve (a valve controller or a 3-way solenoid valve must be used to operate the Model 826 valve (CV of 0.01 or greater)).

Figure 4.
Air-In Port

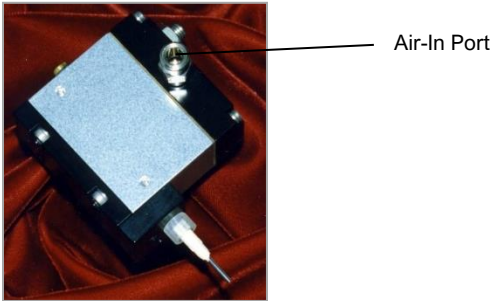

Material Flow & Suck-Back Adjustment

Adjusting Material Flow

Figure 5.
Model 826 Flow Adjustment Procedure Components

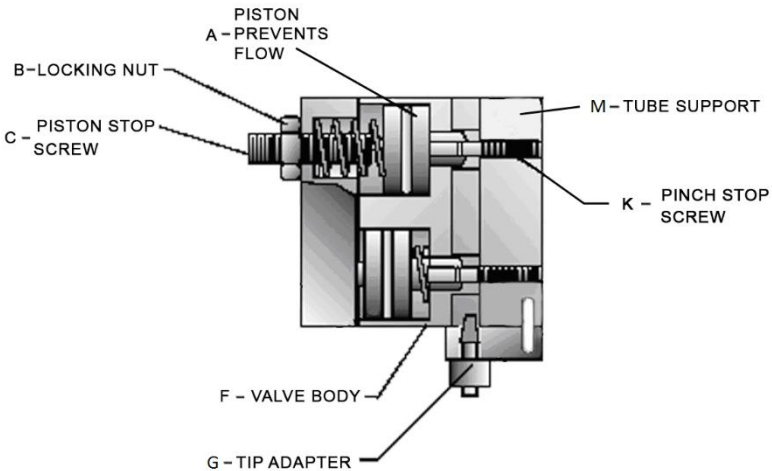

It is very important that the Tube Support (Figure 5, M) be firmly in place for the valve to function properly. Check to be sure that the Tube Support is flush against the Valve Body (Figure 5, F).

To set the Piston (Figure 5, A) for the proper pinch of the fluid path (amount of closing and opening) with the Tube connected to the Material Reservoir, gradually pressurize the Reservoir and adjust the valve-piston pinch using the following steps:

1. Set the Reservoir's pressure to 5 psi [0.3 bar].

Note: If the Pinch Stop Screw (Figure 5, K) prevents the Piston (Figure 5, A) from closing the Tubing, flow will begin as soon as the Reservoir is pressurized.

2. With the hex wrench provided, turn the Pinch Stop Screw (Figure 5, K) counter-clockwise until the Tube is sufficiently closed to stop the flow of material.
3. After the Tube is sufficiently closed, slowly turn the Pinch Stop Screw (Figure 5, K) clockwise until drops of liquid form at the Nozzle Tip (Figure 5, G).
4. Turn the Pinch Stop Screw (Figure 5, K) counter-clockwise just enough to close the Tube and stop the flow, but not to over-pinch it. Turning the screw 15 degrees more than zero-flow will usually provide a correct setting. The Pinch Stop Screw is now correctly set up to provide the minimal wear and tear on the Tube.
5. After adjusting the Pinch Stop Screw (Figure 5, K), loosen the Locking Nut (Figure 5, B) and turn the Piston Stop Screw (Figure 5, C) clockwise until you feel resistance. The resistance you feel is the Piston Adjustment Screw pressing against the Piston (Figure 5, A). The Pinch Stop Screw is now set to a closed position.

Note: You may cut the tubing if you tighten the Piston Adjustment Screw (I) too much.

6. To set the Piston (Figure 5, A) to the desired amount of opening, turn the Piston Stop Screw (Figure 5, C) counter-clockwise from the closed position as described above. Once the desired amount of opening is reached, retighten the Locking Nut (Figure 5, B).

Note: One full turn of the Piston Stop Screw (Figure 5, C) equals 0.042 inches [0.1 cm] of travel.

Adjusting Suck-Back

Figure 6.
Suck-Back Adjustment Procedure Components

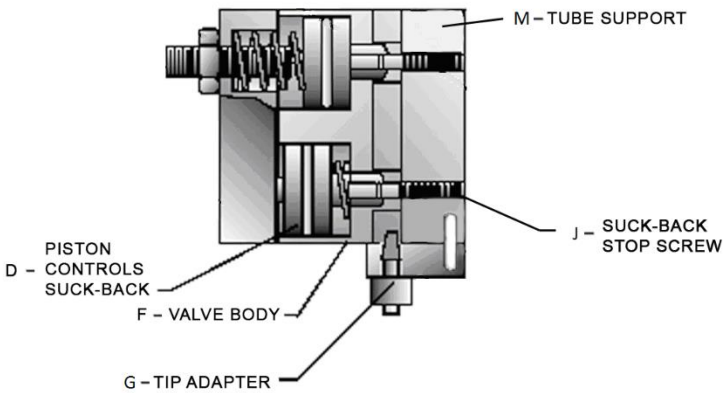

Use the following steps to set the Suck-Back Piston (Figure 6, D):

1. Tighten the Suck-Back Stop Screw (Figure 6, J) clockwise until the screw is bottomed out.
2. Turn the Suck-Back Stop Screw (Figure 6, J) approximately 1/2 a turn counter-clockwise. Greater suck-back is achieved by turning the Suck-Back Stop Screw counter-clockwise.

Operating the Dispensing Valve

Figure 7.
Stages of Valve Operation

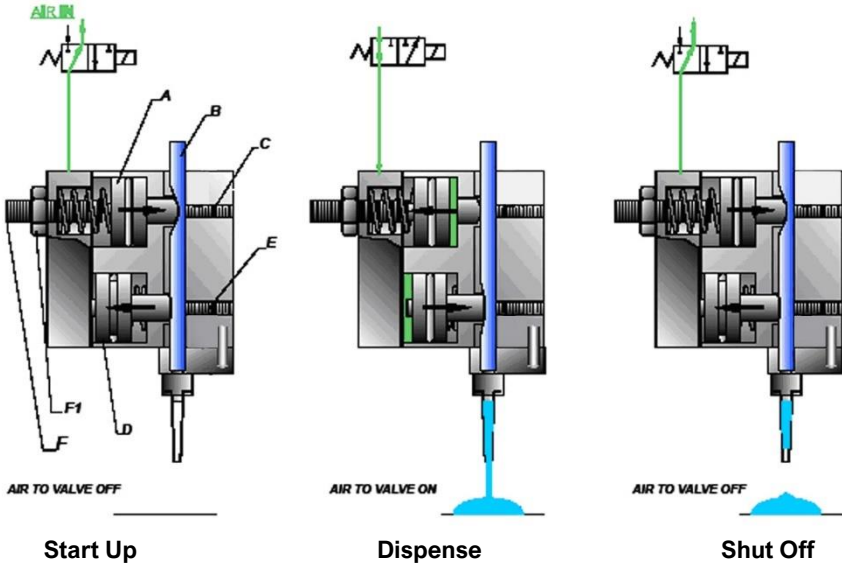

Start Up

When the valve is off/unactuated, the pinching surface of the spring-closed Upper Piston (Figure 7, A) prevents flow by collapsing the Tube (Figure 7, B). The Pinch Stop Adjusting Screw (Figure 7, C) limits the amount of pinch, which limits the stress on the Tube, extends the tubing life, and insures shot repeatability. The blunt Lower Piston (Figure 7, D) is held in its open position by a spring. The Adjusting Screw (Figure 7, E), which determines the amount that this piston will close the tubing when actuated, is set to a position that will allow approximately 50% tube closure.

Dispense

When the valve is on, the air moves the Upper Piston (Figure 7, A) back to the Adjustable Stop (Figure 7, F). This stop controls the amount the tube opens, which in turn controls the rate of flow through the tube. These actions, combined with nozzle size (if a nozzle is used), fluid pressure, and the amount of time the

826 valve is open, governs the amount of fluid dispensed. Simultaneous with the action of the Upper Piston (Figure 7, A), the blunt Lower Piston (Figure 7, D) moves forward until it stops against the Adjusting Screw (Figure 7, E). This causes the piston to partially occlude the Tubing (Figure 7, B).

Shut Off

When the valve is at the end of its dispense cycle, the actuating air exhausts. The upper piston spring moves the Piston (Figure 7, A) forward where it pinches the Tubing (Figure 7, B). At precisely the same moment, the blunt Lower Piston (Figure 7, D) is released so that its spring can also return to its original position. The lower portion of the tube (Figure 7, B) returns to its normal (open) shape. Suck-back is created from the change in the tubing shape. The valve is now ready to repeat the cycle. Fine adjustments can be made to both flow rate and suck-back to obtain the required results.

Troubleshooting

Table 1.
Troubleshooting Chart for Model 826 Dispensing Valve

Problem	Possible Cause	Corrective Action
The valve does not dispense anything	The supply air pressure is too low	Increase the supply air pressure
	Material is cured in the tip	Disassemble and clean the tip
	The flow adjustment is not properly adjusted	Follow the flow adjustment procedure
There are air bubbles in the fluid	The valve is not properly purged	Point the valve up and cycle it until the air bubbles are removed
	There is a problem with the material reservoir and the fluid delivery system	Diagnose and repair
Material leaks from the valve tip	The flow adjustment is not properly adjusted	Follow the flow adjustment procedure
	There is an air bubble trapped in the fluid section of the valve or in the dispense tip	Point the valve up and cycle it until air bubbles are purged out
The dispense rate is too fast	The fluid pressure is set too high	Decrease the fluid pressure
	The dispense tip gauge is too large	Replace the dispense tip with a smaller size tip
	The flow adjustment is not properly adjusted	Follow the flow adjustment procedure
The dispense rate is too slow	The fluid pressure is set too low	Increase the fluid pressure
	The dispense tip gauge is too small	Replace the dispense tip with a larger size tip
	The flow adjustment is not properly adjusted	Follow the flow adjustment procedure

Spare Parts and Accessories

Item	Part Number
Air Regulators	
Filter Regulator	T16307
High-Precision Regulator	T16629
Controllers	
DVC-345 Digital Valve Controller	T11146
Stands	
Lab Stand – 24" [60.96 cm]	T15279
Lab Stand – 8" [20.32 cm] with Mounting Rods	T15449
Tubing	
Black Polyethylene Tubing, 0.25" [0.63 cm] OD, 0.17" [0.43 cm] ID	T15494
Male Luer Barb, Black	T15736
Rebuild Kits	
Valve Rebuild Kit	T17835

Figure 8.
Model 826 Replacement Parts

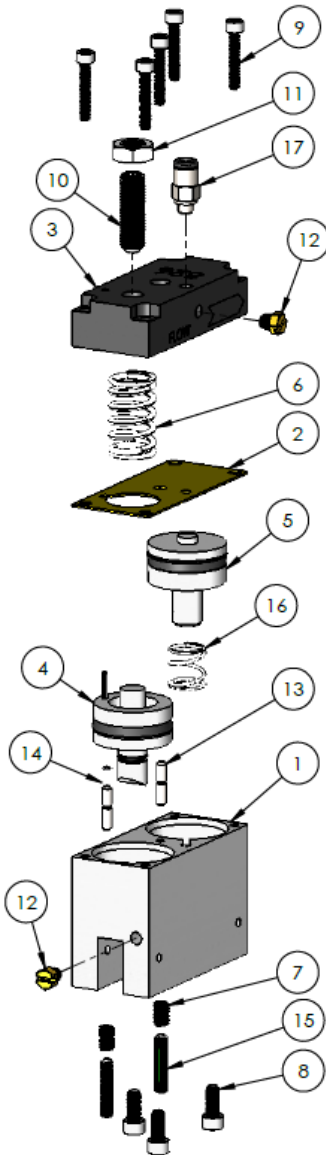

Item	Part Number	Description	Qty.
1	T10938	Model 826 Valve Body	1
2*	T10236	Model 826 Gasket	1
3	T10230	Model 826 End Cap	1
4	T10049	Pinch Piston	1
5*	T15144	U Cup Seals	2
6	T14936	Spring, 0.6 OD x 0.72 WR x 2 L x K26	1
7	T12225	Insert, Screwlock, 8-32, 0.246	2
8	T14209	Socket Head Cap Screw, 8-32, 0.375, 18-8	3
9	T14204	Socket Head Cap Screw, 6-32, 0.75, SS	5
10	T14874	Screw/CPSS/5/16-24/1.0	1
11	T12191	Nut/5/16-24/0.1875/Hexjam	1
12	T11701	Plug, 10-32, Brass, Buna Gasket	2
13	T10235	Pin, Sealing, 455	2
14	T13542	O-Ring, Buna, 0.24 CS x 0.075 ID	2
15	T12341	Screw, SHSS, 8-32, 0.75, SS, Lock	2
16*	T14935	Spring, 0.480 OD x 0.038 WR x 1L, K9.5	1
17	T11702	Fitting, Straight, 10-32, 0.25 OD	1
18*	T16661	Model 826 Wrench Set Kit	1

*Parts included in Model 826 Valve Rebuild Kit
[T17835](#)

Specifications

Property	Specification
Part Numbers	T17586 - Model 826 valve with 0.25" [0.63 cm] OD Polyethylene tubing
Valve Type	Pinch with disposable fluid path
Construction Material	Anodized Aluminum
Operating Air Pressure	60-90 psi [4.1-6.3 bar]
Maximum Inlet Fluid Pressure	Tubing dependent; 100 psi [6.9 bar] maximum (typical)
Maximum Operating Temperature	150°F [65°C]
Maximum Tubing Size	0.25" [0.63 cm] OD
Activation	Valve controller or 3-way solenoid valve
Dimensions (W x H x D)	1.13" x 2.5" x 2.66" [2.87 cm x 6.35 cm x 6.75 cm]
Weight	11 oz [312 kg]
Unit Warranty	1 year from purchase date

Figure 9.

Model 826 Dimensional Drawing

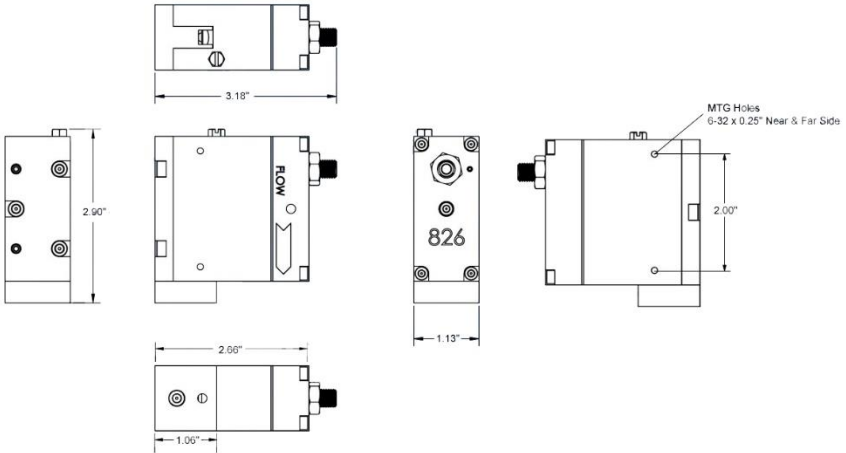

Warranty

From date of purchase, Dymax Corporation offers a one-year warranty against defects in material and workmanship on all system components with proof of purchase and purchase date. Unauthorized repair, modification, or improper use of equipment may void your warranty benefits. The use of aftermarket replacement parts not supplied or approved by Dymax Corporation, will void any effective warranties and may result in damage to the equipment.

IMPORTANT NOTE: DYMAX CORPORATION RESERVES THE RIGHT TO INVALIDATE ANY WARRANTIES, EXPRESSED OR IMPLIED, DUE TO ANY REPAIRS PERFORMED OR ATTEMPTED ON DYMAX EQUIPMENT WITHOUT WRITTEN AUTHORIZATION FROM DYMAX. THOSE CORRECTIVE ACTIONS LISTED ABOVE ARE LIMITED TO THIS AUTHORIZATION.



www.dymax.com

Americas

USA | +1.860.482.1010 | info@dymax.com

Europe

Germany | +49 611.962.7900 | info_de@dymax.com
Ireland | +353 21.237.3016 | info_ie@dymax.com

Asia

Singapore | +65.67522887 | info_ap@dymax.com
Shanghai | +86.21.37285759 | dymaxasia@dymax.com
Shenzhen | +86.755.83485759 | dymaxasia@dymax.com
Hong Kong | +852.2460.7038 | dymaxasia@dymax.com
Korea | +82.31.608.3434 | info_kr@dymax.com

© 2012-2018 Dymax Corporation. All rights reserved. All trademarks in this guide, except where noted, are the property of, or used under license by Dymax Corporation, U.S.A. Teflon® is a registered trademark of DuPont.

Please note that most dispensing system applications are unique. Dymax does not warrant the fitness of the product for the intended application. Any warranty applicable to the product, its application and use is strictly limited to that contained in Dymax standard Conditions of Sale published on our website. Dymax recommends that any intended application be evaluated and tested by the user to ensure that desired performance criteria are satisfied. Dymax is willing to assist users in their performance testing and evaluation. Data sheets are available for valve controllers or pressure pots upon request. T17587 MAN033 10/23/2018